

What's New / 2

What's Important / 3

Model Lineup / 4 - 8

Purchase Motivators	Reference
Performance/Handling / 9 - 11	Audio / 22 - 23
Comfort/Convenience / 12 - 15	Wheels / 24
Safety/Security / 16 - 19	Color and Trim / 25
Design/Styling / 20	Instrument Cluster / 26
Quality/Reliability/Durability / 21	Key Product Specifications / 27
	Accessories / 29 - 30

AdvanceTrac® Electronic Stability Control (ESC) / 16, 17

Airbags

Front-seat Side / 16, 18

First- and Second-row Side Curtain / 16, 18

Anti-theft Systems

Perimeter Alarm / 16, 19

SecuriLock® Passive / 16, 19

Audio Systems

Single-disc CD /MP3 Player / 14, 22

Premium Single-disc CD/MP3 Player / 14, 22

SIRIUS® Satellite Radio / 12, 14, 23

Auxiliary Audio Input Jack / 14, 23

Belt-Minder® / 12, 16

Brakes

Anti-lock Braking System (ABS) / 16, 17

Electronic Brake Force Distribution / 16

Child Safety Locks, Rear Door / 16

Colors, Exterior / 20

Colors, Interior / 20

Door Handles / 20

Engines

2.0L DOHC Duratec I-4 / 9, 10

2.0L DOHC Duratec PZEV I-4 / 9, 10

Duratec Technology / 10

Fuel Economy / 9, 27

LATCH (Lower Anchors and Tethers for Children) System / 16, 19

Lighting, Ambient Interior / 20

Maintenance

Air Filter, PZEV / 21

Oil Change Interval / 21

Spark Plug, 90,000-mile / 21

Message Center / 12, 13

MyKey™ / 12, 13

NVH (Noise, Vibration and Harshness) Enhancements / 21

Packages

Driver's Group / 14

Moon and Tune Package / 14

SE Sedan Appearance Package / 20

SYNC® and Sound Package / 14

Partial Zero Emissions Vehicle (PZEV) Emissions Rating / 9, 10

Personal Safety System™ / 16, 18

Quality / 21

Ratings, Crash Test / 19

Roadside Assistance, 24-Hour / 16, 21

Safety, Structural / 16, 18

Seating

Front Sport Bucket / 12, 13

Leather-trimmed, Heated Front-row / 12

Rear 60/40 Split-fold-flat / 12

Tip/Slide Front-row / 12

SOS Post Crash Alert System / 16

Steering, Rack-and-pinion / 9, 11

Storage / 12

Styling, Exterior / 20

Styling, Interior / 20

Suspension, European-inspired

Independent MacPherson Strut Front Suspension / 9, 11

Control Blade Multi-link Independent Rear Suspension / 9, 11

SYNC® Voice-activated Communications and

Entertainment System / 12, 14, 15

Tire Pressure Monitoring System (TPMS) / 16, 17

Traction Control / 16, 17

Transmissions

5-speed Manual / 10

4-speed Automatic / 10

Trunk

Capacity/Storage / 12

Trunk Release, Emergency / 16

Warranty

Corrosion Perforation / 21

New Vehicle Limited / 21

Powertrain Limited / 21

## WHAT'S NEW

## This page is about:

- Package Changes
- Safety/Security
- Functional Changes
- Interior/Exterior Changes
- Key Competitors

# 2010 Focus

## What's New

### Overview

#### Key Messages

##### FOCUS



- Focus now packs a higher level of safety with AdvanceTrac® electronic stability control and Anti-lock Braking System (ABS) standard on all models
- MyKey™ is an industry-exclusive feature designed to help promote safer driving habits
- SES Sedan and Coupe now drive and look alike with the same sport fascia, black chrome, sport-tuned suspension and 17" wheels

#### Package Changes

- SYNC® and Sound Package now available on SE series
  - SYNC voice-activated communications and entertainment system
  - Driver's Group
  - Premium single-disc CD/MP3 player with 190 watts and 9 speakers (including subwoofer)
- SE Sedan Appearance Package now available on SE Sedan
  - 15" alloy wheels with unique finish
  - Decklid spoiler
  - Fog lamps

#### Safety/Security

- Anti-Lock Brake System (ABS) is now standard on all series
- Perimeter anti-theft system is standard on SE, SES, SEL models

#### Functional Changes

- MyKey is new for 2010 and standard on all models
- AdvanceTrac now standard on all models
- Message Center is now standard on all models
- SYNC voice-activated communications and entertainment system adds 911 Assist™, Vehicle Health Report (VHR) and Traffic, Directions and Information
- All 6-disc CD functionality removed from audio systems, replaced with single-disc

#### Interior Changes

- Remote Keyless Entry and power door locks with trunk release now standard on all models
- Illuminated entry system now standard on all models

#### Exterior Changes

- Optional moonroof on SE models
- 17" Premium painted wheels are standard on SES Sedan
- Sport-tuned suspension is standard on SES Sedan
- Dark chrome grille, headlamp trim, taillamp trim are now standard on the SES Sedan
- Coupe fascia is now standard on SES Sedan
- Chrome fender vent deleted from SEL
- Colors added:
  - Blue Flame Metallic (SZ)
  - Ingot Silver Metallic (UX)
  - Natural Neutral Metallic (UR)
- Colors deleted:
  - Amber Gold Metallic
  - Brilliant Silver Metallic
  - Light Ice Blue Metallic
  - Vista Blue Metallic

#### Key Competitors

- **Toyota Corolla** is positioned as high quality and fuel efficient
- **Honda Civic** offers 6 models including a hybrid and natural gas model
- **Chevrolet Cobalt** targets the performance-oriented small car buyer
- **Hyundai Elantra** features a 10-year/100,000-mile powertrain warranty
- **Saturn ASTRA** — 3-door and 5-door hatchbacks replace the ION

NOTE: See the latest Dealer Ordering Guide for feature availability.

# 2010 Focus

## What's Important

WHAT'S IMPORTANT

This page is about:

Product Highlights

Focus

### Product Highlights

#### KEY FOCUS FEATURES

**Duratec engine lineup is powerful, efficient and environmentally friendly**  
(pgs. 9, 10)

**SYNC®**  
(pgs. 12, 14, 15)

**SIRIUS®  
Satellite Radio**  
(pgs. 12, 14, 23)



**Chassis and European-inspired suspension deliver excellent driving dynamics**  
(pgs. 9, 11)

**AdvanceTrac®**  
(pgs. 16, 17)

**MyKey™**  
(pgs. 12, 13)

#### Performance/Handling

- Powerful, efficient and environmentally friendly engine lineup
  - 2.0L Duratec DOHC I-4 engine
  - 2.0L Duratec DOHC I-4 PZEV engine
- Chassis and European-inspired suspension deliver excellent driving dynamics
- Independent MacPherson strut front suspension and Control Blade multi-link independent rear suspension
- Sport-tuned suspension on SES models
- Brake system includes aluminum front calipers and large front rotors
- Coupe performance axle ratio

#### Comfort/Convenience

- MyKey™
- Generous passenger volume, head room and leg room
- All audio systems feature CD/MP3 capability and auxiliary audio input jack
- SYNC® voice-activated communications and entertainment system
- SIRIUS® Satellite Radio
- 60/40 split-fold-flat rear seatbacks
- Front bucket seats feature improved lateral and lumbar support
- Remote Keyless Entry
- Message Center
- Illuminated entry

#### Safety/Security

- Personal Safety System™
- AdvanceTrac® standard on all models
- Front-seat side airbags
- First- and second-row side curtain airbags
- Anti-lock Braking System (ABS) standard on all models
- All-Speed Traction Control
- SOS Post Crash Alert System
- Tire Pressure Monitoring System (TPMS)
- Perimeter alarm

#### Design/Styling

- SES Sedan exemplifies sportiness and affordability
  - New front fascia
  - New dark chrome headlamp and taillamp treatments
  - 17" Premium painted dark stainless aluminum wheels
- Model lineup with Coupe and Sedan offered in various trim levels
- Ambient interior lighting
- Signature 2-bar grille
- Rear spoiler
- SE Sedan Appearance Package

#### Quality/Reliability/Durability

- Environmentally friendly
- Strong and quiet
- 90,000-mile scheduled spark plug maintenance interval<sup>(1)</sup>
- Extended-life air filter (PZEV)
- 5-year/60,000-mile Powertrain Limited Warranty
- 24-Hour Roadside Assistance

(1) Under normal driving conditions with regular fluid and filter changes. See vehicle Owner's Guide.

**NOTE:** See the latest Dealer Ordering Guide for feature availability.

**MODEL LINEUP**

**This page is about:**

S Sedan

# 2010 Focus Model Lineup

**Model Lineup Pages**

The Model Lineup pages are based on the Dealer Ordering Guide and are designed to show key features/equipment and Rapid Spec content on the 2010 Focus. As you move through the model lineup, each model adds to or upgrades the equipment of the preceding model, except where additions/exemptions are noted. The Focus is available in two models, comprising six series:

**Sedan**

- S
- SE
- SEL
- SES

**Coupe**

- SE
- SES

**S Sedan — Standard model**



**Performance/Handling**

- Brakes — front disc/rear drum
- Duratec® engine
  - 2.0L I-4
  - 2.0L I-4 (PZEV) (standard in California Emissions States)
- Powertrain — front-wheel drive
- Spare tire — mini
- Steering — power rack-and-pinion
- Suspension — European-inspired independent
  - Front MacPherson strut with stabilizer bar
  - Rear Control Blade
- Tires — P195/60R15 87T
- Transmission — 5-speed manual

**Comfort/Convenience**

- Accessory delay
- Audio — single-disc CD/MP3 capability with auxiliary audio input jack, speed-compensated volume and 4 speakers
- Climate control — manual air conditioning
- Console, floor with armrest, small storage bin and metallic clock top plate
- Cup holders — 2 front, 1 rear
- Defroster — rear window
- Dome lamps — front and rear
- Door locks — power
- Floor mats — carpeted, color-keyed
- Glove box
- Horn — single-note
- Illuminated entry
- Instrumentation — tachometer and trip odometer
- Map pocket — passenger front seatback
- Message Center

- Mirror, interior — day/night
- Mirrors, exterior — dual manual
- MyKey™
- Power points — 12V (2)
- Remote Keyless Entry with integrated keyhead transmitters (2)
- Seats — cloth
  - 5-passenger seating with adjustable head restraints
  - Front bucket seats with driver 4-way manual adjust and passenger 2-way manual adjust
  - Rear 60/40 split fold-flat seat
- Storage bin, center stack
- Steering wheel — tilt
- Sun visors (2) with vanity mirrors
- Top-of-dash display
- Trunklid release
- Windows — manual
- Windshield wipers — 2-speed fixed intermittent

**Safety/Security**

- AdvanceTrac®
  - Anti-lock Braking System (ABS)
  - Traction control
- Airbags
  - Dual-stage frontal
  - Front-seat side
  - Side curtain, 1st- and 2nd-row
- Alarm — perimeter
- Battery Saver
- Belt-Minder®
- Child safety locks — rear door
- Emergency trunk release — glow-in-the-dark
- LATCH (Lower Anchors and Tethers for Children) System
- Personal Safety System™
- SecuriLock® passive anti-theft system
- SOS Post Crash Alert System
- Tire Pressure Monitoring System (TPMS)
  - Excludes spare tire

**Design/Styling**

- Bumpers — body color
- Door handles, exterior — black
- Glass — solar-tinted
- Grille — 2-bar, chrome
- Headlamps — halogen
- Instrument cluster — Ice Blue backlighting
- Mirrors, exterior — black
- Safety belts — 3-point for all passengers
- Wheels — 15" steel, 6-spoke cover

**S SEDAN RAPID SPEC OPTIONS**

**Rapid Spec**

**Option Group 100A**

- Includes S Sedan standard equipment

**Freestanding Options**

**Performance/Handling**

- 2.0L Duratec I-4 PZEV engine
- 4-speed automatic transmission

**Comfort/Convenience**

- SIRIUS® Satellite Radio

**NOTE:** The above information is an excerpt to be used with pages 2 and 3 of the 6/1/09 Focus Dealer Ordering Guide. For the latest Dealer Ordering Guide go to [fmcdealer.com](http://fmcdealer.com).

# 2010 Focus

## Model Lineup

### MODEL LINEUP

This page is about:

- SE Sedan —
- SEL Sedan —

#### SE Sedan — Includes all S Sedan content, plus:



##### Comfort/Convenience

- Map reading lamps (2)
- Mirrors, exterior — dual power
- SIRIUS® Satellite Radio
- Windows — power

##### Design/Styling

- SE badge
- Wheels — 15" aluminum

#### SE SEDAN RAPID SPEC OPTIONS

##### Rapid Spec

##### Option Group 200A

- Includes SE Sedan standard equipment

##### Option Group 201A

- Driver's Group
  - Electrochromic auto-dimming inside rearview mirror
  - Cruise control
  - Redundant steering-wheel-mounted audio controls
  - Leather-wrapped steering wheel
- SYNC® voice-activated communications and entertainment system

##### Option Group 202A

- SYNC and Sound Package
  - Driver's Group
  - SYNC voice-activated communications and entertainment system
  - Premium single-disc CD/MP3 player with 190 watts and 9 speakers

##### Freestanding Options

##### Performance/Handling

- 2.0L Duratec I-4 PZEV engine
- 4-speed automatic transmission

##### Comfort/Convenience

- Cruise control (200A only)
- Moonroof
- SE Sedan Appearance Package
  - 15" aluminum wheel with unique finish
  - Fog lamps
  - Decklid spoiler

##### Design/Styling

- Ambient interior lighting

**NOTE:** The above information is an excerpt to be used with pages 4 and 5 of the 6/1/09 Focus Dealer Ordering Guide. For the latest Dealer Ordering Guide go to [fmcdealer.com](http://fmcdealer.com)

#### SEL Sedan — Includes all SE Sedan content, plus:



- Seats — leather-trimmed and heated front
- SYNC voice-activated communications and entertainment system
  - 911 Assist™
  - Vehicle Health Report (VHR)
  - Traffic, Directions and Information

##### Design/Styling

- Ambient interior lighting
- Door handles, exterior — chrome
- Door handles, interior — chrome
- Exhaust tip — chrome
- Instrument cluster — performance with chrome accents
- Mirrors, exterior — chrome caps
- SEL badge
- Wheels — 16" Euroflange aluminum

##### Performance/Handling

- Suspension — enhanced European with rear stabilizer bar
- Tires — P205/50R16 87H

##### Comfort/Convenience

- Compass and outside temperature displays
- Driver's Group
  - Mirror, interior — electrochromic auto-dimming rearview with integrated microphone
  - Steering wheel — leather-wrapped with redundant audio/cruise controls
- Mirrors — dual heated, power

#### SEL SEDAN RAPID SPEC OPTIONS

##### Rapid Spec

##### Option Group 300A

- Includes SEL Sedan standard equipment

##### Option Group 301A

- Moon and Tune Package
  - Premium single-disc CD/MP3 player with 190 watts and 9 speakers
  - Moonroof

##### Freestanding Options

##### Performance/Handling

- 2.0L Duratec I-4 PZEV engine
- 4-speed automatic transmission

**NOTE:** The above information is an excerpt to be used with pages 7 and 8 of the 6/1/09 Focus Dealer Ordering Guide. For the latest Dealer Ordering Guide go to [fmcdealer.com](http://fmcdealer.com).

**MODEL LINEUP****This page is about:**

SES Sedan

# 2010 Focus

## Model Lineup

**SES Sedan** — Includes all SE Sedan content, plus:

**Performance/Handling**

- Suspension — sport-tuned enhanced European-inspired, independent
  - Front MacPherson strut with stabilizer bar
  - Rear Control Blade with stabilizer bar
- Tires — P215/45R17 87H

**Comfort/Convenience**

- Compass and outside temperature display
- Driver's Group
  - Mirror, interior — electrochromic auto-dimming with integrated microphone
  - Steering wheel — leather-wrapped, with redundant audio/cruise controls
- Mirrors, exterior — dual heated, power
- SYNC<sup>®</sup> voice-activated communications and entertainment system
  - 911 Assist<sup>™</sup>
  - Vehicle Health Report (VHR)
  - Traffic, Directions and Information

**Design/Styling**

- Ambient interior lighting
- Door handles, exterior — body color
- Door handles, interior — chrome
- Exhaust tip — chrome
- Fascias — sport front and rear
- Fog lamps
- Headlamp trim — dark chrome
- Instrument cluster — performance with chrome accents
- Instrument panel appliqué — metallic
- Mirrors, exterior — body-color cap
- Rear decklid spoiler
- Register vents — chrome accents
- Spoiler decklid
- SES badge
- Taillamp trim — dark chrome
- Wheels — 17" Premium painted aluminum

**SES SEDAN RAPID SPEC OPTIONS****Rapid Spec****Option Group 400A**

- Includes SES Sedan standard equipment

**Option Group 401A**

- Moon and Tune Package
  - Premium single-disc CD/MP3 player with 190 watts and 9 speakers
  - Moonroof

**Freestanding Options****Performance/Handling**

- 2.0L Duratec I-4 PZEV engine
- 4-speed automatic transmission

**Comfort/Convenience**

- Leather-trimmed, heated front seats

**NOTE:** The above information is an excerpt to be used with pages 9 and 10 of the 6/1/09 Focus Dealer Ordering Guide. For the latest Dealer Ordering Guide go to [fmcdealer.com](http://fmcdealer.com).

# 2010 Focus

## Model Lineup

### MODEL LINEUP

This page is about:

SE Coupe

Focus

### SE Coupe — Standard coupe model



#### Performance/Handling

- Brakes — front disc/rear drum
- Duratec® engine
  - 2.0L I-4
  - 2.0L I-4 (PZEV) (standard for California Emission States)
- Exhaust — Sport
- Powertrain — front-wheel drive
- Spare tire — mini
- Steering — power rack-and-pinion
- Suspension — Enhanced European-inspired independent
  - Front MacPherson strut with stabilizer bar
  - Rear Control Blade with stabilizer bar
- Tires — P205/50R16 87H
- Transmission — 5-speed manual

#### Comfort/Convenience

- Accessory delay
- Audio — single-disc CD/MP3 capability with auxiliary audio input jack, speed-compensated volume and 4 speakers
- Climate control — manual air conditioning
- Console, floor with armrest, small storage bin and metallic clock top plate
- Cup holders — 2 front, 1 rear
- Defroster — rear window
- Dome lamps — front and rear
- Door locks — power
- Floor mats — carpeted, color-keyed
- Glove box
- Horn — single-note
- Illuminated entry
- Instrumentation — tachometer and trip odometer
- Map lamps (2)
- Map pocket — passenger front seatback
- Message Center

- MyKey™
- Mirrors, exterior — dual heated, power
- Mirror, interior — day/night
- Power points — 12V (2)
- Remote Keyless Entry with trunk release transmitters (2)
- Seats — cloth
  - 5-passenger seating with adjustable head restraints
  - Front bucket with driver 4-way manual adjust and passenger 2-way manual adjust
  - Rear 60/40 split fold-flat
- SIRIUS® Satellite Radio
- Steering wheel — tilt
- Storage bin, center stack
- Sun visors (2) with vanity mirrors
- Top-of-dash display
- Windows — power
- Windshield wipers — 2-speed fixed intermittent

#### Safety/Security

- AdvanceTrac®
  - Anti-lock Braking System (ABS)
  - Traction control
- Airbags
  - Dual-stage frontal
  - Front-seat side
  - Side curtain, 1st- and 2nd-row
- Battery Saver
- BeltMinder®
- Child safety locks — rear door
- Emergency trunk release — glow-in-the-dark
- LATCH (Lower Anchors and Tethers for Children) System
- Personal Safety System™
- Safety belts — 3-point for all passengers
- SecurILock® passive anti-theft system
- SOS Post Crash Alert System
- Tire Pressure Monitoring System (TPMS)

#### Design/Styling

- Bumpers — body color
- Door handles, exterior — body color
- Exhaust tip — chrome
- Fog lamps
- Glass — solar-tinted
- Grille — 2-bar, dark chrome
- Headlamp trim — dark chrome
- Instrument cluster — black appliqué with white-faced gauges, Ice Blue backlighting
- Instrument panel appliqué — metallic
- Mirrors, exterior — body color caps
- SE badge
- Spoiler — trunklid
- Taillamp trim — dark chrome
- Wheels — 16" aluminum

#### SE COUPE RAPID SPEC OPTIONS

##### Rapid Spec

##### Option Group 200A

- Includes SE Coupe standard equipment

##### Option Group 201A

- Driver's Group
  - Electrochromic auto-dimming inside rearview mirror
  - Cruise control
  - Redundant steering-wheel-mounted audio controls
  - Leather-wrapped steering wheel
- SYNC® voice-activated communications and entertainment system

##### Option Group 202A

- SYNC and Sound Package
  - Driver's Group
  - SYNC voice-activated communications and entertainment system
  - Premium single-disc CD/MP3 player with 190 watts and 9 speakers

##### Freestanding Options

##### Performance/Handling

- 2.0L Duratec I-4 PZEV engine
- 4-speed automatic transmission

##### Comfort/Convenience

- Cruise control (200A only)
- Moonroof

##### Design/Styling

- Ambient interior lighting

**NOTE:** The above information is an excerpt to be used with pages 4 and 5 of the 6/1/09 Focus Dealer Ordering Guide. For the latest Dealer Ordering Guide go to [fmcdealer.com](http://fmcdealer.com).

**MODEL LINEUP****This page is about:**

SES Coupe

# 2010 Focus

## Model Lineup

**SES Coupe** — Includes all SE Coupe content, plus:

**Performance/Handling**

- Suspension — sport-tuned enhanced European-inspired, independent
  - Front MacPherson strut with stabilizer bar
  - Rear Control Blade with stabilizer bar
- Tires — P215/45R17 87H

**Comfort/Convenience**

- Compass and outside temperature displays
- Driver's Group
  - Electrochromic auto-dimming inside rearview mirror
  - Cruise control
  - Redundant steering-wheel-mounted audio controls
  - Leather-wrapped steering wheel
- SYNC® voice-activated communications and entertainment system
  - 911 Assist™
  - Vehicle Health Report (VHR)
  - Traffic, Directions and Information

**Design/Styling**

- Ambient interior lighting
- Door handles, interior — chrome
- Instrument cluster — performance with chrome accents
- Register vents — chrome accents
- SES badge
- Spoiler — high-mount roof
- Steering wheel appliqué
- Wheels — 17" Premium painted dark stainless aluminum

**SES COUPE RAPID SPEC OPTIONS****Rapid Spec****Option Group 400A**

- Includes SES Coupe standard equipment

**Option Group 401A**

- Moon and Tune Package
  - Premium single-disc CD/MP3 player with 190 watts and 9 speakers
  - Moonroof

**Freestanding Options****Performance/Handling**

- 2.0L Duratec I-4 PZEV engine
- 4-speed automatic transmission

**Comfort/Convenience**

- Leather-trimmed, heated front seats

**NOTE:** The above information is an excerpt to be used with pages 9 and 10 of the 6/1/09 Focus Dealer Ordering Guide. For the latest Dealer Ordering Guide go to [fmcdealer.com](http://fmcdealer.com).

# 2010 Focus

## Performance/Handling

### PERFORMANCE/HANDLING

#### This page is about:

- 2.0L Duratec® I-4 Engine
- 2.0L Duratec I-4 PZEV Engine
- European-inspired Suspension
- Sport-tuned Suspension
- EPA-estimated Fuel Economy
- What Is a PZEV?

## Overview

### Key Messages

#### Focus



- Focus continues to offer a powerful, efficient and environmentally friendly powertrain lineup
- European inspired-independent suspension systems provide a smooth ride and handling
- Every Focus is equipped with a 5-speed manual transmission; a 4-speed automatic transmission is optional
- Focus SES is equipped with a sport-tuned suspension and 17" Premium painted aluminum wheels

### Key Features

#### Powertrain

**Cast aluminum cylinder head and engine block** reduces overall vehicle weight and provides optimized combustion performance.

**2.0L Duratec® I-4 engine** features a 16-valve dual overhead cam (DOHC) design that delivers 140 horsepower and features a cast aluminum block and cylinder head. This engine can be teamed with a 5-speed manual or a 4-speed automatic transmission.

**2.0L Duratec I-4 PZEV engine** also features a 16-valve DOHC design that delivers 136 horsepower and a lightweight aluminum block and cylinder heads. This engine, teamed with either the 5-speed manual transmission or the 4-speed automatic transmission, meets the Partial Zero Emissions Vehicle (PZEV) standard. The PZEV rating applies to California Emissions States.

#### Chassis

**A stiff chassis** with rigid mounting points absorbs road harshness and delivers precise response to steering inputs, for exceptional ride and handling characteristics.

**European-inspired independent MacPherson strut front suspension** uses friction-reducing geometry for precise tuning of the shock absorber valves, for remarkable ride and handling.

**European-inspired Control Blade multi-link independent rear suspension** delivers an excellent balance of ride and handling and is built on an isolated subframe to reduce interior vibration and harshness.

**Sport-tuned suspension** is standard on SES Coupe and Sedan models and delivers the ultimate in Focus handling performance. Chassis enhancements include revised strut and shock absorber tuning, revised steering component tuning, larger stabilizer bars and 17" wheels.

**Rack-and-pinion steering** delivers linear steering effort and a responsive steering feel.

EPA-estimated Fuel Economy	City mpg	Highway mpg
5-speed manual	24	35
4-speed automatic	24	34

### A CLOSER LOOK: What Is a PZEV?

A Partial Zero Emissions Vehicle (PZEV) is certified to emit no more than 6.5 pounds of hydrocarbon pollutants over 120,000 miles of driving. By comparison, a vehicle certified to the California Low Emissions Vehicle (LEV II) or Federal Tier 2 Bin 5 emissions standard emits about 29 pounds over 120,000 miles.

Under today's criteria, vehicles that achieve a PZEV rating earn 9.5 on the Environmental Protection Agency's Green Vehicle Guides. Only a zero emissions vehicle (battery electric or fuel cell) receives a better score.<sup>(1)</sup>

To achieve a PZEV rating, a vehicle must meet certain criteria, including:

- Meet the super ultra-low emissions vehicle (SULEV) standard for tailpipe pollution
- Demonstrate zero fuel-based evaporative emissions
- The manufacturer's warranty must ensure that emissions-related components are covered for 15 years/150,000 miles<sup>(2)</sup>

(1) PZEV and LEV-II calculations include both tailpipe and evaporative emissions.  
 (2) See page 10 for more emissions-related warranty information.

**PERFORMANCE/HANDLING****This page is about:**

- Duratec® Technology
- 2.0L Duratec DOHC I-4 Engine
- 2.0L Duratec DOHC I-4 PZEV Engine
- 5-speed Manual Transmission
- 4-speed Automatic Transmission

# 2010 Focus

## Performance/Handling

### Powertrain

#### Duratec® Technology

- Cast aluminum engine block and cylinder head reduces overall vehicle weight
- DOHC 16-valve cylinder head delivers excellent combustion performance for a balance of horsepower and fuel efficiency
- Timing chain, instead of a belt, helps improve durability.
- Low NVH (Noise, Vibration and Harshness) characteristics make for a smooth ride and quiet interior
- Hardened camshaft lobes help eliminate valve adjustments during a useful life of 10 years or 150,000 miles under normal driving conditions

#### 2.0L Duratec DOHC I-4 Engine

- 140 horsepower @ 6000 rpm and 136 lb.-ft. of torque @ 4250 rpm
- Standard in every state except CA, CT, MA, ME, NJ, NY, OR, PA, RI, VT, WA
- Certified as Federal Tier 2 Bin 4; qualifies as Ultra Low Emissions Vehicle (ULEV II)

#### 2.0L Duratec DOHC I-4 PZEV (Partial Zero Emissions Vehicle) Engine

- 136 horsepower @ 6000 rpm
- 133 lb.-ft. of torque @ 4250 rpm
- Standard in all models delivered to CA, CT, MA, ME, NJ, NY, OR, PA, RI, VT, WA
- Available as a limited option for orders submitted by dealers in the cross border states of AZ, DE, ID, MD, NH, NV, OH, WV
- Meets zero fuel-based emissions standards by demonstrating zero fuel-based evaporative emissions
- Ford covers the emissions performance of its California-emissions-certified PZEVs registered in CA, CT, MA, ME, NJ, NY, RI and VT with a 15-year or 150,000-mile (whichever occurs first) limited warranty on emissions components (OR, PA and WA do not require the extended PZEV warranty)
- Scores a 9.5 (10 is the highest score) on the EPA's Green Vehicle Guide ([epa.gov/greenvehicles/Index.do](http://epa.gov/greenvehicles/Index.do)). Only a Zero Emissions Vehicle (battery electric or fuel cell) receives a higher score

#### 5-Speed Manual Transmission

- Fully synchronized synchromesh for all gear ratios, for smooth shifting
- Low friction needle-roller bearings and synthetic oil help improve fuel economy
- Low-effort shifter and clutch are easy to operate and lend a smooth ride
- Final Drive Ratio:
  - 3.56 with 15" wheels
  - 3.82 with 16" and 17" wheels

#### 4-Speed Automatic Transmission

- Electronic Synchronous Shift Control works with the Power PC to calculate the best possible shifting strategy
- Overdrive fourth gear reduces engine rpm at highway speed. This improves fuel economy and makes for a smooth, quiet ride
- Extremely compact and lightweight
- Final Drive Ratio:
  - 3.34
  - 4.20 SES Coupe only



# 2010 Focus

## Performance/Handling

### PERFORMANCE/HANDLING

#### This page is about:

- European-inspired Independent MacPherson Strut Front Suspension
- European-inspired Control Blade Multi-link Independent Rear Suspension
- Rack-and-pinion Steering
- Enhanced European-inspired Suspension

## Chassis

### European-inspired Independent MacPherson Strut Front Suspension

- MacPherson strut design with a rearward-facing L-arm gives the maximum amount of room in front of the suspension to help improve crash performance
- Friction-reducing geometry helps engineers precisely tune the strut valving for remarkable ride and handling
- Suspension bushings are tuned independently for responsive steering and a smooth ride
- Use of hydrobushings in critical locations helps isolate the body from the suspension
- A large bushing at the top of the MacPherson strut mount helps resist vertical movements that occur on uneven road surfaces. It also resists side deflection to keep a crisp steering feel
- Coil-over-shock design puts the shock right in the center of the coil spring. The reduced offset limits twisting or lateral forces that could bind the shock and cause a harsher ride
- A hydrobushing at the rear of the lower control arm uses oil-filled internal chambers to dampen road forces before they reach the passenger compartment

### European-inspired Control Blade Multi-link Independent Rear Suspension

- Each wheel reacts independently to bumps and rough pavement, providing a smooth ride without sacrificing handling
- Independent design helps reduce impact of road imperfections into the passenger cabin, helps reduce interior vibration and harshness and gives Focus a smooth ride
- Compact design minimizes intrusion into the trunk

### Rack-and-pinion Steering

- Rack-and-pinion steering maintains linear steering effort as the driver turns the wheel. The result is responsive steering that naturally follows a straight line as the wheel is turned
- Tight 34.2-foot (curb-to-curb) turning diameter
- Quick steering ratio of 15.8:1 means drivers don't have to turn the wheel very far to go around a tight corner

### Enhanced European-inspired Suspension

- Standard on Coupe and Sedan models with 16" wheels
- Upgraded suspension with revised strut and shock absorber tuning for less rebound
- Larger 22mm front stabilizer bar
- 18mm rear stabilizer bar
- Provides more aggressive cornering capability to the already smooth comfortable ride

### Sport-tuned Suspension

- Standard on SES Coupe and Sedan models
- Delivers the ultimate in Focus handling performance with:
  - Revised strut and shock absorber tuning
  - Revised steering assembly tuning
  - 22mm front stabilizer bar
  - Larger 20mm rear stabilizer bar
  - 17" wheels with P215/50R17 tires



## COMFORT/CONVENIENCE

## This page is about:

- Seating
- MyKey™
- SYNC®
- SIRIUS® Satellite Radio
- Storage
- Remote Keyless Entry

# 2010 Focus

## Comfort/Convenience

### Overview

#### Key Messages

##### Focus



- New MyKey™ offers fleet owners and parents of teenage drivers peace of mind
- SYNC® voice-activated communications and entertainment system includes Traffic, Directions and Information functionality for 2010
- SIRIUS® Satellite Radio
- SEL Sedan offers outstanding luxury and affordability
- CD/MP3 capability on every Focus audio system

#### Key Features

##### Seating

**Front Sport bucket seats** offer excellent lateral and lumbar support as well as 4-way adjustability for the driver. Coupe models include a Tip/Slide feature to help ease rear seat access.

**60/40 split-fold-flat rear seatbacks** provide maximum passenger and/or cargo-carrying flexibility.

**Leather-trimmed, heated front seats** offer additional comfort and luxury. Contrast stitching on the bolsters provides an upscale appearance.

##### Exterior

**Large 13.8-cu.-ft. trunk** offers plenty of room for luggage and a large opening to help make loading and unloading easier.

##### Interior

**MyKey** is standard on all Focus models and allows parents or fleet owners to help increase the safety of at-risk drivers, such as teenagers, with the ability to:

- Restrict vehicle top speed
- Restrict maximum audio system volume
- Establish a persistent Belt-Minder® alert that mutes the audio system until front safety belts are fastened
- Establish an earlier Low Fuel Warning indicator
- Restrict the disabling of certain features, if equipped

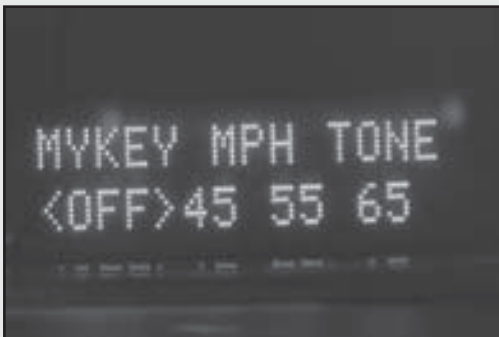

##### Interior cont'd

**SYNC** voice-activated communications and entertainment system<sup>(1)</sup> now includes Traffic, Directions and functionality for 2010. This latest version of SYNC provides access to turn-by-turn directions, personalized traffic reports and business search (411) — all accessed by voice commands — in addition to 911 Assist™ and Vehicle Health Report (VHR) functionality. See page 15 for more information.

**SIRIUS Satellite Radio** provides over 130 channels, digital sound quality and coast-to-coast coverage.

**“Top-of-dash” display** places key information at eye level so driver spends less time looking away from the road.

##### Storage, and more storage...

- Door trim panels with map pockets and molded-in bottle holders
- Instrument panel center stack storage bin
- Front-row armrest with integrated storage compartment
- Map pocket behind passenger seatback
- Glove box

##### Remote Keyless Entry with Integrated Keyhead

**Transmitter and trunk release** replaces the standard key and separate Remote Keyless Entry fob combination with a single integrated keyhead transmitter.

**Message Center** monitors various vehicle systems to improve driver-to-vehicle awareness, including an instantaneous mpg display to help maximize fuel-efficient driving habits.



(1) Driving while distracted can result in loss of vehicle control. Only use mobile phones and other devices, even with voice commands, when it's safe to do so.

# 2010 Focus

## Comfort/Convenience

### COMFORT/CONVENIENCE

#### This page is about:

Large Cargo Area	—
High Roofline	—
MyKey™	—
Integrated Instrument Panel Center Stack	—
Seats	—
Interior Storage	—

## Exterior

### Large Cargo Area

- Both models offer 13.8 cu. ft. of luggage capacity
- Large trunk opening makes it easy to load and unload items. The trunk holds two regular-size suitcases standing side by side
- Counterbalanced gas struts assist in lifting the trunklid and don't fold into the trunk taking up precious usable space
- Compact design of the Control Blade independent multi-link rear suspension reduces cargo space intrusion

### High Roofline

- Maximizes interior passenger volume and head room
- Provides plenty of room for friends and cargo
- Allows Focus to have more interior volume than some competitors

## Interior

### MyKey™

- A Ford Motor Company first and an industry exclusive
- Standard on all Focus models
- Allows owners to program a "key limit" to certain vehicle functions to help promote safe driving habits
- Default restrictions include:
  - Persistent Belt-Minder® alert that mutes audio system until front safety belts are fastened
  - Earlier Low Fuel Warning indicator
  - Restriction of disabling certain features, if equipped
- Programmable restrictions include:
  - Limited vehicle top speed
  - Speed alert chimes (45, 55 or 65 mph)
  - Maximum audio system volume
- Programming MyKey is done via the Message Center
  - One standard key will be the Administrator Key while the other will operate as MyKey with the programmed restrictions

### Integrated Instrument Panel Center Stack

- Houses the controls for audio and climate controls, and auxiliary audio input jack
- Includes two auxiliary power outlets
- "Top-of-dash" display places key information at eye level so driver spends less time looking away from the road
  - Displays include audio system function, time and SYNC® (if equipped)
  - Displays outside temperature and compass when equipped with SYNC



### Front Sport Bucket Seats

- Feature high-quality padding and seat materials for increased lateral and lumbar support to provide improved comfort
- Include adjustable head restraints and passenger-side map pocket
- Coupe models have Tip/Slide feature for easy access to the rear seats
- 4-way manual adjustment for driver's seat
- 2-way manual adjustment for passenger seat
- Available leather-trimmed front bucket seats provide extra comfort and luxury as well as a modern appearance of contrasting color thread stitching

### 60/40 Split-fold-flat Rear Seatbacks

- Provide maximum passenger and cargo-carrying flexibility
- One seatback can be folded flat to accommodate longer items while still providing a rear seating position for a passenger or both seatbacks can be folded for extra cargo space

### Interior Storage

- Front door trim panels include pocket storage and large, molded-in bottle holders
- Larger center console includes bonus storage at the base of the center stack as well as primary storage under the armrest

### Remote Keyless Entry with Integrated Keyhead Transmitter and Trunk Release

- Replaces the standard key and separate Remote Keyless Entry fob combination with a single integrated keyhead transmitter
- System operates all door locks and trunk and includes a panic button

### Message Center

- Monitors various vehicle systems, such as fluid levels, improving driver-to-vehicle awareness
- Displays instantaneous fuel economy

## COMFORT/CONVENIENCE

## This page is about:

- Groups and Packages
- Audio Systems
- SIRIUS® Satellite Radio
- SYNC®

# 2010 Focus

## Comfort/Convenience

### Groups and Packages

#### Driver's Group

- Electrochromic auto-dimming inside rearview mirror
- Cruise control
- Redundant steering-wheel-mounted audio controls
- Leather-wrapped steering wheel

#### Moon and Tune Package

- Premium single-disc CD/MP3 player with 190 watts and 9 speakers
- Moonroof

#### SYNC® and Sound Package

- Driver's Group
- SYNC voice-activated communications and entertainment system
- Premium single-disc CD/MP3 player with 190 watts and 9 speakers

### Audio/Entertainment Systems

#### Audio Systems

- Single-disc CD/MP3 capability
- Premium single-disc CD/MP3 capability with 190 watts and 9 speakers
- Auxiliary audio input jack

**NOTE:** See pages 22 and 23 for more information.

#### SIRIUS® Satellite Radio

- 6-month complimentary subscription subject to geographic location and availability
- Over 130 channels
- Commercial-free music
- Digital sound quality
- Seamless coverage anywhere in the 48 contiguous states and Washington, D.C.

**NOTE:** See page 23 for more information.

#### SYNC®<sup>(1)</sup>

Ford and Microsoft® have teamed up to develop SYNC. This Ford-exclusive technology will change the way customers use their digital media and Bluetooth®<sup>(2)</sup> wireless technology enabled mobile phones. SYNC allows drivers to stay connected to the information, entertainment and people they care about while on the road. SYNC features:

- Traffic, Directions and Information (new for 2010)
  - Includes complimentary 3-year prepaid subscription
- 911 Assist™
- Vehicle Health Report (VHR)
- Voice-activated hands-free calling
- Uninterrupted connections that allow going directly from mobile phone to the vehicle's hands-free phone during the call
- Audible text messages
- Advanced calling features like caller ID, call waiting, conference calling and more
- Voice-activated control of an MP3-style media player
- Instant voice recognition
- Ringtone support
- Automatic phone book transfer for mobile phones with this feature
- Multilingual intelligence (English, French, Spanish)
- For more information, go to [syncmyride.com](http://syncmyride.com)

(1) Driving while distracted can result in loss of vehicle control. Only use mobile phones and other devices, even with voice commands, when it's safe to do so.

(2) The Bluetooth word mark is a trademark of the Bluetooth, SIG, Inc.

# 2010 Focus

## Comfort/Convenience

COMFORT/CONVENIENCE

This page is about:

Traffic, Directions and Information

911 Assist™

Vehicle Health Report (VHR)

Focus

## SYNC® Technology

### Traffic, Directions and Information<sup>(1)</sup>

- Ford-exclusive technology
- Includes complimentary 3-year prepaid subscription
- Provides simple voice command access to traffic reports, turn-by-turn driving directions, business listings, sports scores, weather forecasts and news
- Updatable by logging on to [syncmyride.com](http://syncmyride.com)
- **Traffic** provides traffic reports between two points, such as home and work
  - Also provides text message traffic alerts to the owner's mobile phone
  - Customers can use their online SYNC owner account to set up personalized address points
- **Directions** provide easy-to-understand in-vehicle driving directions to businesses, personalized locations or specific street addresses
  - The Directions service uses the same personalized address points that are used for Traffic
- **Information** provides access to:
  - Business Search by name or category with results provided in vehicle, including turn-by-turn directions and telephone number
  - News reports in a variety of categories
  - Sports scores
  - Weather information for a number of U.S. cities
  - Favorites allows customers quick access to their favorite news, sports and weather information

### 911 Assist™

- Assists occupants in placing a 911 call in certain vehicle crashes by using a properly paired and connected mobile phone inside the vehicle<sup>(2)</sup>
- Occupants can cancel the call by pressing and holding the phone button on the steering wheel, or by confirming the cancellation message on the Navigation System screen
- Connects to a 911 operator informing them of the accident
- Opens the SYNC microphone to allow vehicle occupants to communicate hands-free with the 911 operator

### Vehicle Health Report (VHR)<sup>(1)</sup>

- Produces an easy-to-understand report accessible on [syncmyride.com](http://syncmyride.com)
- Customers are able to monitor the operating condition of their vehicle and work closely with the dealership to keep it in peak running condition
- VHR combines data from multiple sources to communicate diagnostic, recall and maintenance information
- Provides the capability to seamlessly schedule dealership service via the dealer Web site, via Genuine Service or by e-mail
- Vehicle Health Overview includes:
  - Brakes and suspension
  - Checks, fluids and filters
  - Engine, transmissions and emissions systems
  - Restraints and driver assistance
- Will notify the customer of:
  - Recommended scheduled maintenance based on current odometer reading
  - Recalls and Field Service Actions requested by Ford Motor Company to repair certain safety- or emissions-related concerns

(1) Driving while distracted can result in loss of vehicle control. Only use mobile phones and other devices, even with voice commands, when it's safe to do so.

(2) The vehicle electrical system (including the battery), the wireless service provider's signal and a connected mobile phone all must be available and operating for 911 Assist to function properly. These systems may become damaged in a crash. The paired mobile phone must be connected to SYNC and the 911 Assist feature enabled for 911 to be dialed.

## SAFETY/SECURITY

## This page is about:

- Accident Avoidance
- Occupant Protection
- Child Safety
- Personal Security
- The Ford Commitment to Safety

# 2010 Focus

## Safety/Security

### Overview

#### Key Messages

##### Focus



- AdvanceTrac® is now standard on all models
- Personal Safety System™ provides outstanding passenger protection in certain frontal crashes
- Six total airbags include dual-stage front airbags, front-seat side airbags and side curtain airbags to help protect passengers in certain side impacts
- Traction Control helps provide maximum traction on slippery surfaces

#### Key Features

##### Accident Avoidance

**Traction Control** helps provide control by limiting wheel spin to maximize available traction.

**AdvanceTrac** helps the driver maintain vehicle stability in adverse driving situations or when making evasive maneuvers on slippery pavement.

**Four-wheel Anti-lock Braking System (ABS)** prevents wheel lock during excessive braking to help maintain steering control.

**Electronic Brake Force Distribution** automatically balances the front-to-rear brake force distribution to reduce the tendency for rear-wheel lockup and optimize braking performance according to vehicle load of passengers and/or cargo.

**Tire Pressure Monitoring System (TPMS)** monitors actual tire pressure of the road wheels and alerts driver if a tire is significantly underinflated.

##### Occupant Protection

**Personal Safety System™** deploys dual-stage front airbags based on crash severity, safety belt usage, driver's-seat position and front-passenger weight classification.

**Front-seat side airbags** help protect front-seat occupants in certain side collisions.

**First- and second-row side curtain airbags** offer head protection in side impacts for front and rear outboard-seated passengers.

**"Safety cell" construction** utilizes extensive use of high-strength steel to provide an energy-absorbing structure to help protect occupants in a collision.

**Side-door intrusion beams** help prevent intrusion into the passenger compartment in a side-impact collision.

**3-point safety belts** for all seating positions.

**Belt-Minder®** chimes and flashes the safety belt warning light for up to 5 minutes or until the driver and/or passenger fasten their safety belts.

##### Child Safety

**LATCH (Lower Anchors and Tethers for Children) System** helps provide secure and proper installation of LATCH-compatible child safety seats.

**Rear-door child safety locks** prevent rear-seat occupants from opening the doors from the inside.

**Emergency trunk release** allows a person accidentally locked in the trunk to escape.

##### Personal Security

**SOS Post Crash Alert System** activates the hazard flashers and sounds the horn after a crash in which the airbags deploy.<sup>(1)</sup> Sounding the horn and flashing the hazards makes the vehicle easier to locate if the accident happens off the roadway. System operates until deactivated or battery power is depleted.

**Perimeter alarm** helps prevent unauthorized entry when the vehicle is locked.

**SecuriLock® passive anti-theft system** requires an electronically coded key (with billions of possible codes) to start the vehicle.

**24-Hour Roadside Assistance** provides roadside service for items such as running out of gas, a flat tire, jump starts, etc., for 5 years or 60,000 miles, whichever comes first.

(1) SOS hardware may become damaged or the battery may lose power in a crash, which could prevent operation. Not all crashes will activate an airbag.

#### The Ford Commitment to Safety

New vehicle buyers expect a high level of built-in safety. Fulfill these expectations by demonstrating the comprehensive system of safety features engineered into every Ford vehicle.

- Demonstrate vehicle safety as a complete, integrated system, not as a list of individual features. Almost every design aspect — even down to such small details as the layout of the air conditioning controls — figures into the total safety picture
- Unlike any other vehicle feature or concept, every customer is concerned about safety to some degree
- Safety features "sell" — a convincing presentation combining safety and other motivators can win over prospects who are considering other brands
- Some safety features are more obvious than others. It's important to point out that there's much more to safety than airbags and safety belts
- See the Safety section in the Source Book Appendices or on **eSourceBook** for more information

# 2010 Focus

## Safety/Security

### SAFETY/SECURITY

#### This page is about:

- AdvanceTrac®
- Traction Control
- Four-wheel Anti-lock Braking System (ABS)
- Tire Pressure Monitoring System (TPMS)

## Accident Avoidance

### AdvanceTrac®

- An electronic stability control system that helps the driver maintain vehicle control in adverse driving situations or when making evasive maneuvers on slippery pavement
- Monitors vehicle's cornering behavior with steering angle, lateral acceleration and yaw rate sensors, and automatically makes braking and throttle adjustments to match vehicle's direction to the driver's intention using Anti-lock Braking System (ABS) and Traction Control components
- AdvanceTrac automatically activates whenever the vehicle is started, but may be turned off for certain situations such as when "rocking" a vehicle stuck in mud or snow

**NOTE:** See the Safety section in the Source Book Appendices or on **eSourceBook** for more information.

### Traction Control

- Included with AdvanceTrac and uses engine control to reduce engine power (torque) to the drive wheels and help maximize available traction on slippery or loose driving surfaces at any speed

### Four-wheel Anti-lock Braking System (ABS)

- Included with AdvanceTrac and helps drivers to maintain steering control in emergency or other hard-braking situations
- Electronically "pumps" the brakes several times per second when the computer-controlled sensors indicate wheel lockup during hard braking

### Tire Pressure Monitoring System (TPMS)

- Sensor-based system alerts the driver to significant underinflation in any of the tires, excluding the spare
- Pressure sensors detect actual tire pressure and activate a warning light in the vehicle's Message Center when a tire is significantly underinflated

**NOTE:** See the Safety section in the Source Book Appendices or on **eSourceBook** for more information.



## SAFETY/SECURITY

**This page is about:**

- Personal Safety System™
- Structural Safety
- Rear-seat Head Restraints
- Front-seat Side Airbags
- First- and Second-row Side Curtain Airbags
- Roll-fold Technology

# 2010 Focus

## Safety/Security

### Occupant Protection

#### Personal Safety System™

The Ford Personal Safety System tailors airbag usage to the severity of the crash, driver and passenger safety belt use, driver's-seat position and passenger classification. System components include:

- Dual-stage driver and front passenger airbags
- Electronic front crash severity sensor
- Driver's-seat position sensor
- Front outboard safety belt usage sensor
- Restraint Control Module
- Front outboard safety belt energy management retractors
- Front outboard safety belt pretensioners
- Front Passenger Sensing System

**NOTE:** See the Safety section in the Source Book Appendices or on **eSourceBook** for more information.

#### Structural Safety

- "Safety cell" construction and structural rigidity provide crash management in the event of some accidents
- Front and rear crumple zones progressively deform to help absorb impact energy and reduce the amount of crash forces reaching the passenger compartment
- Side door intrusion beams help prevent intrusion into the passenger compartment in a side-impact collision

#### Rear-seat Head Restraints

- Help provide an extra level of protection for rear-seat occupants, especially in rear impacts

#### Front-seat Side Airbags

- Side-impact airbags help protect front-seat occupants in certain side collisions
- Airbags deploy from the front seats to protect occupants' chest
- Airbags are placed in the front seatbacks, so they are always in the correct deployment position no matter where the seat is positioned

#### First- and Second-row Side Curtain Airbags

- System offers head protection in side impacts for all outboard seating positions
- Side curtain airbags are located in the roof side rail behind the headliner and are triggered independently of the driver and front passenger airbags
- Side curtain airbags will not interfere with a properly installed child safety seat or booster seat
- Combined with the front-seat side airbags, the side curtain airbags help provide protection for both head and chest in certain side-impact collisions
- Air curtains feature "roll fold" technology
  - Deploys the airbags from the headliners alongside the interior panels and windows
  - If an occupant's head is against a window, the airbag is designed to slide between the glass and the occupant as it fills

### PRESENTATION TIP: Roll-fold Technology

One of the keys to outstanding safety protection with Focus is the side curtain airbags. These airbags are concealed in the headliner and employ roll-fold technology to help ensure proper deployment during certain side-impact collisions and rollovers. You can demonstrate how this safety feature functions using a simple "blow-out" or "roll horn" party favor since it uses the same basic principles as the roll-fold technology.

Give it a try:

- Insert the roll horn into your mouth and inflate it
- Air pressure enters the horn and flows out to unfold and inflate (or pressurize) the rolled end of the horn
- Consider tilting your head down while inflating the horn to demonstrate the downward deployment of the airbag along the side of the window
- Explain to the customer before or after you inflate the horn — sensors inflate the side curtain airbags in a fraction of a second — what they're seeing happens faster than the eye can see
- While the unfolding and inflating process is nearly impossible to see with the naked eye, the rolled party favor works much the same way

# 2010 Focus

## Safety/Security

### SAFETY/SECURITY

This page is about:

- Crash Test Ratings
- LATCH (Lower Anchors and Tethers for Children) System
- SecuriLock® Passive Anti-theft System
- 24-Hour Roadside Assistance

## Crash Test Ratings

### NHTSA

Focus Coupe received the highest possible ratings in frontal crash testing performed by the National Highway Traffic Safety Administration (NHTSA).

- In the full frontal test, vehicles are crashed into a fixed barrier at 35 mph, which is like a head-on collision between two similar vehicles, each moving at 35 mph
- Side-impact crash test represents an intersection-type collision with a 3015-lb. barrier moving at 38.5 mph into a standing vehicle
- Full frontal crash ratings should only be compared between vehicles within the same weight class (plus or minus 250 lbs.)
- For a complete list of NHTSA results, visit [safercar.gov](http://safercar.gov)

	Frontal-impact Rating		Side-impact Rating	
	Driver	Passenger	Front Seat	Rear Seat
Focus Sedan	★★★★	★★★★	★★★★★	★★★★
Focus Coupe	★★★★★	★★★★★	★★★	★★★

### What Do the Stars Mean?

#### Frontal-impact Testing

★★★★★ 5 stars = 10 percent or less chance of serious injury

#### Side-impact Testing

★★★★★ 5 stars = 5 percent or less chance of serious injury

★★★★ 4 stars = 6 to 10 percent chance of serious injury

★★★ 3 stars = 11 to 20 percent chance of serious injury

### IIHS

2009 Focus Sedan received the highest possible ratings in frontal offset and rear-impact testing and the 2009 Focus Coupe was named a "Top Safety Pick" by the Insurance Institute for Highway Safety (IIHS). 2010 Focus is expected to receive the same ratings when tested.

**Frontal Offset Test** — vehicle impacts a fixed barrier at 40 mph. Only half of the vehicle's front surface makes contact with the barrier.

**Side-impact Test** — a 3300-lb. barrier moving at 31 mph strikes the side of a stationary vehicle.

**Rear-impact Test** — the vehicle's front seat is mounted on a platform which is accelerated forward. This simulates the stationary vehicle being hit from behind and tests for whiplash injury.

Focus Results		
IIHS Test	Sedan Test Evaluation Result	Coupe Test Evaluation Result
Frontal Offset	<b>G</b> Good	<b>G</b> Good
Side Impact	<b>A</b> Acceptable	<b>G</b> Good
Rear Impact	<b>G</b> Good	<b>G</b> Good
Stability Control	Available <sup>(1)</sup>	Available <sup>(1)</sup>

(1) Focus features standard AdvanceTrac electronic stability control.

## Child Safety

### LATCH (Lower Anchors and Tethers for Children) System

- Consists of a top tether anchor point and two rigid bars located where the seat cushion meets the seatback
- All rear seats offer LATCH provisions
- LATCH-compatible child safety seat attaches to the lower anchor points by means of flexible tethers or rigid latch bars
- LATCH assists in providing a secure attachment and uniform installation method to help reduce the likelihood of an improper child safety seat installation

### SecuriLock® Passive Anti-theft System

- Uses an electronically coded ignition key (with billions of possible codes)
- Designed to help prevent the engine from being started unless a coded key programmed to the vehicle is used

### Perimeter Alarm

- Monitors unauthorized entry of the doors and hood

## Personal Security

### 24-Hour Roadside Assistance

- Toll-free number (1-800-241-FORD) is operational 24 hours, 7 days a week
- Customers can request services to change a flat tire, jump-start a battery, deliver fuel or tow the vehicle
- Available for 5 years or 60,000 miles, whichever comes first

## DESIGN/STYLING

## This page is about:

- Chrome Signature 2-bar Grille
- New SE Sedan Appearance Package
- SES/SEL Distinctions
- Wheels
- Exterior Colors
- Ambient Interior Lighting

# 2010 Focus

## Design/Styling

### Overview

#### Key Messages

##### Focus



- New SE Sedan Appearance Package offers a sporty look, while maintaining a strong value story
- Three new colors in the exterior color palette
- Ambient interior lighting adds a personalized touch to the interior
- Focus Coupe attracts the attention of the sport enthusiast
- Focus Sedan appeals to the practical, family-oriented customer

#### Key Features

##### Exterior

**Chrome signature 2-bar grille** introduces the bold Focus style to the road ahead. SES models feature a sporty dark chrome finish.

**High beltline** provides sleek and modern proportions.

**Muscular wheel arches** frame a distinctive wheel lineup.

**Rear spoilers** add to the sporty look of Focus. Coupe SES features a rally-inspired high-mount rear spoiler.

##### New SE Sedan Appearance Package

- 15" aluminum wheel with machined face and dark painted pockets
- Fog lamps
- Decklid spoiler

##### SES Distinctions

- Dark chrome grille (new for SES Sedan)
- Dark chrome headlamp and taillamp trim (new for SES Sedan)
- Sport front fascia (new for SES Sedan)
- Fog lamps
- Body-color door handles
- 17" Premium painted (Dark Stainless) aluminum wheel (new for SES Sedan)
- Rear spoiler
  - Decklid on Sedan
  - High-mount on Coupe

##### SEL Distinctions

- Leather-trimmed seating with heated front row
- Chrome door handles
- Chrome heated mirrors
- 16" Euroflange wheels

##### Wheels

- 15" steel wheel with 6-spoke cover
- 15" aluminum wheel
- 15" aluminum wheel with machined face and dark painted pockets
- 16" 6-spoke aluminum wheel
- 16" 6-spoke Euroflange aluminum wheel
- 17" Premium painted (Dark Stainless) aluminum wheel

##### Exterior Colors

- New Blue Flame Metallic
- New Ingot Silver Metallic
- New Natural Neutral Metallic
- Ebony
- Sangria Red Metallic
- Sterling Grey Metallic
- White Suede
- See page 25 for availability

##### Interior

##### Ambient interior lighting

- LEDs (Light-Emitting Diodes) illuminate the front and rear footwells and cup holders for a soft colorful glow
- Colors can be changed with the mood, offering seven different color choices (red, green, blue, yellow, aqua, purple and white)
- Complements the Ice Blue backlighting of the instrument cluster and interior controls

##### Interior Colors

- Medium Light Stone
- Charcoal Black
- See page 25 for availability

# 2010 Focus

## Quality/Reliability/Durability

**QUALITY/RELIABILITY/DURABILITY**

**This page is about:**

- NVH (Noise, Vibration and Harshness) —
- New Vehicle Limited Warranty —
- Quality Claims —
- Durability —
- Environmental —
- 24-Hour Roadside Assistance —

Focus

## Overview

### Key Messages

#### Focus



- Aerodynamic and chassis structure improvements and additional interior sound-deadening greatly improve interior quietness
- Environmentally friendly Duratec engines meet more stringent Federal and California emissions standards
- Spark plugs and chain-driven overhead camshaft help contribute to easy maintenance, with a 90,000-mile spark plug maintenance interval under normal driving conditions
- Powertrain warranty protection for 5 years/60,000 miles

### Key Features

#### Quality

##### NVH (Noise, Vibration and Harshness)

- Extra-stiff dash panel in the area of the cowl top to help reduce stress and associated noise
- Climate control system performs efficiently and operates quietly
- Overall airflow over the exterior was improved in 2009, reducing the coefficient of drag from 0.33 to 0.32. This helps reduce the amount of wind noise heard inside the cabin and helps improve real-world fuel economy
- Acoustic windshield, thick side-door glass and closed-cell foam for the dash panel seal all help to reduce wind noise
- Sound-absorption material in the door trim panels, C-pillar trim and the flat shelf behind the rear seat helps reduce cabin noise

##### New Vehicle Limited Warranty

- 3-year/36,000-mile Bumper-to-Bumper; no deductible
- 5-year/unlimited-mileage Corrosion Perforation
- 5-year/60,000-mile Powertrain Limited Warranty:
  - Powertrain Limited Warranty for Ford vehicles is 5 years or 60,000 miles, whichever comes first
  - That's an additional 2 years/24,000 miles of coverage for components such as the engine, transmission and front- and rear-wheel-drive parts beyond the vehicle's 3-year/36,000-mile Bumper-to-Bumper Limited Warranty
  - Refer to the vehicle Warranty Guide for a complete list of all of the parts covered

##### Quality Claims<sup>(1)</sup>

- No compact car has better quality than Ford Focus
- Ford Focus has quality equal to Toyota Corolla, Nissan Sentra and Honda Civic
- Ford Focus has quality equal to the best compact cars Japan can offer

#### Durability

- Long-life Duratec engine components, such as the chain-driven dual camshafts, offer outstanding durability with no required valve adjustments for 150,000 miles
- Body-color 5-mph bumpers are rated at twice the federal requirement and help resist sheet metal damage from minor front and rear impacts
- 6-month/7,500-mile oil change interval
- Spark plugs are rated for 90,000 miles under normal driving conditions
- Extended-life air filter is designed to last 15 years or 150,000 miles, whichever comes first, under normal driving conditions (PZEV)

#### Environmental

- Optimized gear ratios and carefully calibrated powertrains help deliver impressive real-world fuel economy
- 2.0L Duratec DOHC I-4 engine is certified to meet Federal Tier 2 Bin 4 emissions standards and qualifies for California Ultra Low Emission Vehicle (ULEV II) emissions standard
- 2.0L Duratec DOHC I-4 PZEV engine meets the requirements for a Partial Zero Emissions Vehicle (PZEV) in the California Emissions States (CA, CT, MA, ME, NJ, NY, OR, PA, RI, VT, WA)

#### 24-Hour Roadside Assistance

- Toll-free number (1-800-241-FORD) operational 24 hours a day, every day
- Customers can request services to change flat tire, jump-start battery, unlock vehicle, deliver fuel or tow vehicle
- Available for 5 years or 60,000 miles, whichever comes first

(1) Based on RDA Group's GQRS cumulative survey at 3 months of service in 3 surveys of 2008 Ford and competitive owners conducted 9/07-5/08.

## AUDIO

## This page is about:

- Single-disc CD/MP3 Player
- Premium Single-disc CD/MP3 Player

## 2010 Focus

## Audio

## All Focus Audio Systems Include

- Station Memory Presets — 12 FM, 6 AM
- Autoset (AST) automatically locates 6 strongest AM or FM station signals
- Auxiliary audio input jack
- MP3 capability
- Digital clock

## Single-disc CD/MP3 Player

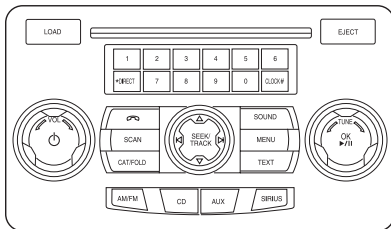

- 144 watts of power
- 4 speakers
- **Speed Compensated Volume (SCV)** compensates for changing ambient noise levels by adjusting the volume of the radio according to the vehicle's speed signal. Allows 7 volume adjustment levels. Adjustable through the menu
- **Compression** allows the audio dynamic range to be compressed so quieter music is boosted and louder music is lowered to compensate for ambient noise level when enabled during CD mode
- **Repeat** will play the selected track continuously until Repeat is deactivated when enabled during CD mode
- **Shuffle** plays CD/MP3 tracks in random order
- **Folder** button allows access to the MP3 folder
- **RBDS (Radio Broadcast Data System) function** allows the following:
  - Only for FM radio stations supporting RBDS capability
  - Radio station call letters appear on display
  - Type of music format appears on display
  - Search for type of music format
  - Traffic information broadcasts
- **Folder/track mode** allows the audio system to play and seek through disc tracks with or without folder option (available with MP3 discs only)
- Displays track time, track being played and total number of tracks
- Text display (ID3 tag, directory and track display)
- Redundant audio controls located on steering column
- Audio system information shown in "top-of-dash" display

## Premium Single-disc CD/MP3 Player

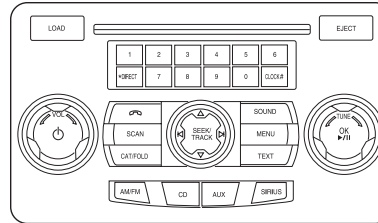

Includes or replaces features of single-disc CD/MP3 capability plus:

- 190 watts of system power
- 500 watts of peak power
- External amp provides maximum power of 110 watts
- 9 speakers in 4 locations plus trunk-mounted subwoofer
  - Coaxial design that combines a tweeter and woofer into one unit
  - Polypropylene cone woofers
  - Butyl rubber surround
  - Rare neodymium magnet
  - Soft cloth dome tweeters (for smooth high-frequency response)
- Subwoofer
  - 8" with separate 110-watt amplifier
  - Heavy-duty dual voice coil speaker
  - 2.4-pound magnet (for tight, crisp bass and high-power performance)
  - Blow-molded enclosure uses little trunk space

## For More Audio Information

- Audio availability: See the latest Dealer Ordering Guide
- Operating information: See the vehicle Owner's Guide

# 2010 Focus

## Audio

AUDIO

This page is about:

SIRIUS® Satellite Radio —  
Auxiliary Audio Input Jack —

Focus

### SIRIUS® Satellite Radio

- Includes 6 months of SIRIUS service subject to geographical location and availability
- Order Code 97S must be specified. This will equip the vehicle with necessary vehicle-to-radio interface and antenna
- Unit is preactivated from the factory
- SIRIUS Satellite Radio can be accessed using existing radio head controls:
  - **Aux button** — press and release to enter satellite radio mode
  - **Seek/Scan** — use these buttons to change channels
- Key benefits of SIRIUS Satellite Radio include:
  - Over 130 channels of the best music, talk, news, sports and information (65 music channels)
  - 100 percent commercial-free music
  - Seamless coverage anywhere in the 48 contiguous states and Washington, D.C.
- More information is available online at [www.sirius.com](http://www.sirius.com) or toll-free at (888) 539-SIRIUS (7474)

### Auxiliary Audio Input Jack



- Standard with all audio systems
- Located at the base of the instrument panel center stack
- Allows the use of most portable MP3 players
- Vehicle audio system will not control the functions of the MP3 player

#### For More Audio Information

- Audio availability: See the latest Dealer Ordering Guide
- Operating information: See the vehicle Owner's Guide







## WHEELS

## This page is about:

- 15" Steel with 6-Spoke Cover
- 15" Aluminum
- 15" Aluminum with Machined Face
- 16" 6-Spoke Aluminum
- 16" 6-Spoke Euroflange Aluminum
- 17" Premium Painted

# 2010 Focus

## Wheels

Wheel		Coupe	Sedan
15" Steel with 6-Spoke Cover		—	Standard on S
15" Aluminum		—	Standard on SE
15" Aluminum with Machined Face and Dark Painted Pockets		—	Included in SE Sedan Appearance Package
16" 6-Spoke Aluminum		Standard on SE	—
16" 6-Spoke Euroflange Aluminum		—	Standard on SEL
17" Premium Painted (Dark Stainless)		Standard on SES	Standard on SES Sedan

— = Not available

**NOTE:** See the latest Dealer Ordering Guide for wheel availability.

# 2010 Focus

## Color and Trim

### COLOR AND TRIM

This page is about:

Color and Trim Availability —  
Interior Trim —

### Color and Trim Availability

Paint Name	Order Code	S and SE Coupe		S Sedan	SE Sedan		SEL Sedan		SES Coupe/Sedan	
		Cloth		Cloth	Cloth		Leather		Cloth/Leather	
		Charcoal Black	Medium Stone	Medium Stone	Charcoal Black	Medium Stone	Charcoal Black	Medium Stone	Charcoal Black	Medium Stone
		FW	FS	GS	FW	FS	HW	HS	GW/HW	GS/HS
New Blue Flame Metallic	SZ	■	■	■	■	■	■	■	■	■
New Ingot Silver Metallic	UX	■	■		■	■	■	■	■	■
New Natural Neutral Metallic	UR			■	■	■	■	■		
Ebony	UA	■	■	■	■	■	■	■	■	■
Sangria Red Metallic	JV	■	■	■	■	■	■	■	■	■
Sterling Grey Metallic	UJ	■	■	■	■	■	■	■	■	■
White Suede	WS			■	■	■	■	■		

### Interior Trim

Model	Style/Material	Interior Description
SE Coupe and Sedan	Cloth	Cloth Sport front bucket seats with 60/40 split fold-flat rear seat (5-passenger)
SES Coupe and Sedan	Cloth	Cloth Sport front bucket seats with 60/40 split fold-flat rear seat (5-passenger)
SES Coupe and Sedan	Leather	Sport leather-trimmed, heated front bucket seats and 60/40 split fold-flat rear seat (5-passenger)
S Sedan	Cloth	Cloth Sport front bucket seats with 60/40 split fold-flat rear seat (5-passenger)
SEL Sedan	Leather	Sport leather-trimmed, heated front bucket seats and 60/40 split fold-flat rear seat (5-passenger)

**NOTE:** See the 2010 Color & Upholstery Selections Guide or the Specifications section on eSourceBook for illustrations of the available seating choices.

**INSTRUMENT CLUSTER**

**This page is about:**

Instrument Cluster

# 2010 Focus

## Instrument Cluster

### Instrument Cluster

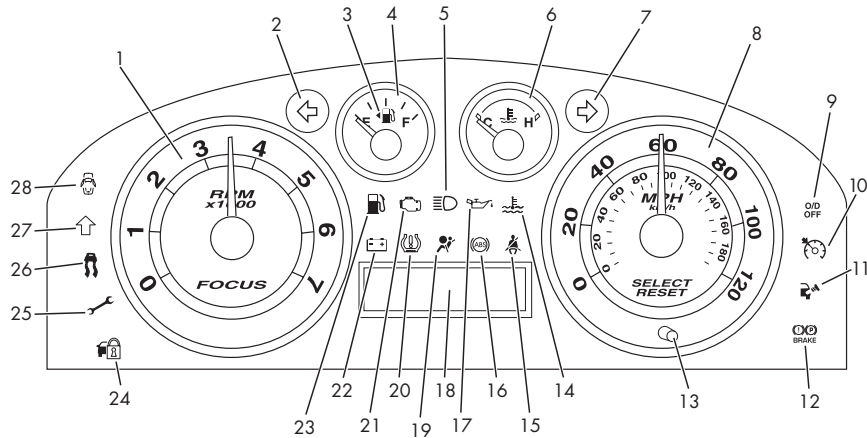

- |  |  |  |
|--|--|--|
| 1. Tachometer                                      | 12. Brake system warning light/parking brake indicator         | 20. Low tire pressure warning light                      |
| 2. Left turn signal indicator                      | 13. Message Center select/reset button                         | 21. Check engine warning light                           |
| 3. Fuel filler door location indicator             | 14. Engine coolant temperature warning light                   | 22. Charging system warning light                        |
| 4. Fuel gauge                                      | 15. Fasten safety belt warning light                           | 23. Low fuel warning light                               |
| 5. High-beam indicator                             | 16. Anti-lock Braking System readiness indicator/warning light | 24. Anti-theft system active indicator                   |
| 6. Engine coolant temperature gauge                | 17. Low engine oil pressure warning light                      | 25. Throttle control/transmission fault warning light    |
| 7. Right turn signal indicator                     | 18. Message Center display                                     | 26. AdvanceTrac®/traction control active indicator light |
| 8. Speedometer                                     | 19. Airbag readiness indicator/warning light                   | 27. Upshift indicator light <sup>(3)</sup>               |
| 9. Overdrive off indicator <sup>(1)</sup>          |  | 28. Door ajar warning light                              |
| 10. Cruise control active indicator <sup>(2)</sup> |  |  |
| 11. Loose fuel cap warning light                   |  |  |

(1) Automatic transmission only. (2) If equipped. (3) Manual transmission only.

# 2010 Focus

## Key Product Specifications<sup>(1)</sup>

### KEY PRODUCT SPECIFICATIONS

Model	Coupe	Sedan
Wheelbase	102.9	102.9
Length	175.0	175.0
Height	58.6	58.6
Width	67.9	67.8
Track (Front/Rear)	58.6/58.1	58.6/58.1
Curb Weight (approx. lbs.)	2638 (manual) 2667 (automatic)	2672 (manual) 2691 (automatic)

Front/Rear Seating		
Seating Capacity	5	5
Head Room (Front/Rear)	39.2/38.3	39.2/38.3
Shoulder Room (Front/Rear)	53.5/53.7	53.4/53.6
Hip Room (Front/Rear)	50.4/48.3	50.4/50.9
Leg Room (Front/Rear)	41.7/36.1	41.7/36.1

Passenger/Luggage/Fuel Capacity		
Passenger Volume (cu. ft.)	93.3	93.4
Luggage Capacity (cu. ft.) (rear seat up)	13.8	13.8
Liftover Height	29.6	29.5
Fuel Tank Capacity (gal.)	13.5	13.5
Total Interior Volume (cu. ft.)	107.1	107.2

Engine	
Engine Layout	Front engine, front-wheel drive
Engine Type	2.0L Duratec DOHC I-4/ 2.0L Duratec DOHC I-4 PZEV
Displacement (liters/cu. in.)	2.0/121
Horsepower @ rpm	140 @ 6000 <sup>(2)</sup> /136 @ 6000
Torque (lb.-ft. @ rpm) (2.0L/2.0L PZEV)	136 @ 4250/133 @ 4250
Compression Ratio	10.0:1
Bore and Stroke	3.44 x 3.27
Fuel System	Sequential Multi-port Electronic Fuel Injection
Fuel Requirement	87 octane (minimum)
Exhaust System	Single, with catalytic converter and flex coupling

EPA-estimated Fuel Economy	
2.0L with manual transmission (City/Hwy. mpg)	24/35
2.0L with automatic transmission (City/Hwy. mpg)	24/34
2.0L PZEV with manual transmission (City/Hwy. mpg)	24/35
2.0L PZEV with automatic transmission (City/Hwy. mpg)	24/34

Transmission	
Type	5-speed manual Electronically controlled 4-speed automatic
Final Drive Ratio	3.56:1 (2.0L DOHC I-4 w/5-spd. man. transmission and 15" wheels) 3.82:1 (2.0L DOHC I-4 w/5-spd. man. transmission w/16- and 17" wheels) 3.34:1 (2.0L DOHC I-4 w/4-spd. auto. transmission) 4.20:1 (2.0L DOHC I-4 w/4-spd. auto. transmission; SES Coupe only)

Gear Ratios						
Gears	1st	2nd	3rd	4th	5th	Rev.
5-Speed Man. (15" wheels)	3.67	2.14	1.45	1.03	0.77	3.72
5-Speed Man. (16" wheels)	3.42	2.14	1.45	1.03	0.77	3.73
4-Speed Automatic	2.82	1.50	1.00	0.73	—	2.65

Chassis Construction	
Type	Unitized body with solid-mounted front subframe

Front Suspension	
Type	Independent MacPherson struts with angled coil spring/damper units and Reverse-L on lower control arms in optimized double horizontal bushings mounted on separate front subframe
Springs	Helical coil
Shock Absorbers	Integral strut, gas-charged hydraulic
Stabilizer Bar	21mm on S and SE Sedan
Diameter	22mm on SE & SES Coupe/SES & SEL Sedan

Rear Suspension	
Type	Independent SLA system with one upper and two lower arms plus additional twist-plate longitudinal link, separate vertical damper units. Preassembled as self-supporting unit mounted on crossmember
Springs	Helical coil
Shock Absorbers	Gas-charged hydraulic
Stabilizer Bar	18mm on SES Coupe and SEL Sedan
Diameter	20mm on SES Coupe and Sedan

Steering	
Type	Power-assisted, rack-and-pinion
Overall Ratio	15.8:1
Turning Diameter, Curb-to-Curb (ft.)	34.2

Brakes	
Standard	Dual circuit, diagonally split, hydraulically operated front disc and rear drum with Anti-lock Braking System (ABS)

Aerodynamics	
Coefficient of Drag (C <sub>d</sub> )	0.32

Trailer Towing <sup>(3)</sup>	
Towing Class	Light-duty Class I
Gross Trailer Weight (lbs.)	1000 max.
Max. Tongue Load (lbs.)	100 max.
Hitch Design	Load-carrying type

Flat/Neutral Towing	
Emergency Towing	It is recommended that Focus be towed with a front-wheel lift or with flatbed equipment.
Recreational Towing	Focus equipped with a manual transmission may be flat towed behind another vehicle, such as an RV. There are no speed or distance restrictions for flat towing the vehicle with a manual transmission. Be sure to remind your customers that the vehicle must be placed in Neutral before flat towing. Front-wheel dollies or a flatbed trailer may also be used for recreational towing.

(1) Dimensions are in inches unless otherwise specified.

(2) 143 horsepower on Coupe models with manual transmission.

(3) See the RV & Trailer Towing Guide, available on eSourceBook as a printable PDF, or the vehicle Owner's Guide for more towing information.

This page left intentionally blank.

# 2010 Focus

## Custom Accessories

### From the "Wow Factory"

FORD CUSTOM ACCESSORIES

This page is about:

Available Custom Accessories  
Selling Ford Custom Accessories

Focus



### The Following Ford Custom Accessories Are Available for the 2010 Focus:

#### Appearance

- 4-, 5- and 6-Piece Body Kits – available painted or unpainted
- Chrome Exhaust Tip
- Spoilers

#### Wheels

- Wheel Locks

#### Electronics

- Fog Lamps
- Garmin® nüvi® Portable Navigation Systems
- Keyless Entry Keypad
- Remote Start Systems
- Smart Alert™ GPS Tracking & Recovery Systems
- Vehicle Security System
- Wiper Shaker

#### Exterior

- Hood Deflector
- Side Window Deflectors
- Splash Guards – Flat
- Splash Guards – Molded
- Vinyl Stripe Kits

#### Interior

- Ash Cup/Coin Holder
- Cargo Area Protector
- Cargo Net
- Electrochromic Rearview Mirrors
- Floor Mats – All-Weather Vinyl
- Interior Lighting Kit
- Katzkin® Leather-Trimmed Seating
- Soft-Sided Cargo Organizers – Folding
- Soft-Sided Cooler Bag
- Stainless Steel Door Sill Plates

#### Selling Ford Custom Accessories

- Offer Custom Accessories to every customer
- Most new vehicle owners want to personalize their ride
- Add Custom Accessories into the deal for just a few dollars more
- Use the online "Accessorizer" to show customers how their vehicle will look
- Use your dealership's Accessories Storefront to boost awareness and sales
- Only you can offer Custom Accessories covered by the Ford New Vehicle Limited Warranty

custom  
accessories 

fordaccessories.com



**FORD CUSTOM ACCESSORIES**

**This page is about:**

- Custom Accessories e-Commerce Program Enrollment
- Selling Ford Custom Accessories Online

# 2010 Focus

## Custom Accessories e-Commerce

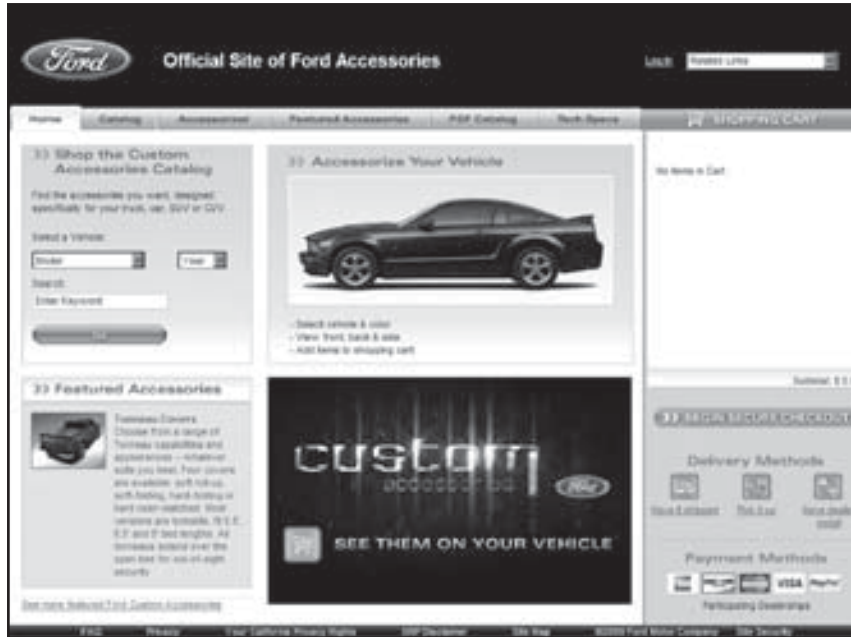

**Sell Custom Accessories 24/7 – Day and Night!**

Once enrolled, the Accessories e-Commerce Web site allows dealers to accept and process customer orders via the Internet.

**CREATE CUSTOM PRICING, EVEN INCLUDE INSTALLATION!**

**e-Commerce Web Site Features**

- Accepts customer accessory orders via the Internet
- Offers customers full range of payment options including PayPal™, Visa®, MasterCard®, AMEX®, Discover® and Genuine Credit Card
- Allows dealers to set their own pricing for parts and labor or use Suggested Retail Pricing
- Allows customers to schedule an accessory installation at dealer via Genuine eService
- FedEx® shipping options to the customer's home or business, automatically billed to your FedEx account

**Enroll Today**

- Complete enrollment details are posted at the Accessories B2B Web site accessed from **FMCDdealer.com**
- <http://accessories.dealerconnection.com/GfaWeb/contentMgmt.do>
- Go to: Reference Library/eCommerce Website Tools

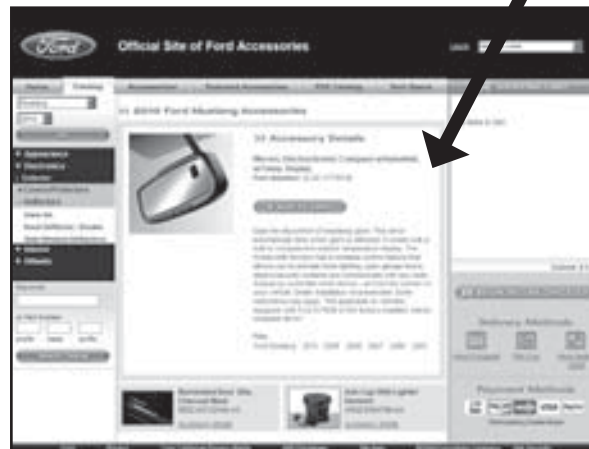

**Great Site, Great Features**

- A fully functional site allowing customers to shop, select and purchase online.
- Allows enrolled dealers the ability to customize their accessory pricing, including installation.
- Allows customers the ability to schedule an accessory installation at the dealership via Genuine eService.
- Offers customers a full range of payment options including PayPal, credit card, Genuine Credit Card.
- Allows customers to select delivery options.

