

What's New / 2

What's Important / 3

Model Lineup / 4 - 7

Purchase Motivators	Reference
Design/Styling / 8 - 10	Audio/Navigation/Entertainment / 24 - 26
Performance/Handling / 11 - 13	Wheels / 27
Comfort/Convenience / 14 - 19	Color and Trim / 28
Safety/Security / 20 - 22	Instrument Cluster / 29
Quality/Reliability/Durability / 23	Key Product Specifications / 30
	Accessories / 31 - 32

AdvanceTrac® with RSC® (Roll Stability Control™) / 20, 21
 Airbags, Front-seat Side / 20, 22
 All-Wheel Drive (AWD) / 11, 13, 20, 21
 Anti-theft System
 Perimeter / 20
 SecuriLock® Passive / 20, 22
 Audio Systems
 Single-disc CD/MP3 Capability / 18, 24
 Premium Sound System 6-disc In-dash CD/MP3 Capability / 18, 24
 SIRIUS® Satellite Radio / 18, 26
 Auxiliary Audio Input Jack / 26
 Blind Spot Exterior Mirrors / 14, 15
 Brakes
 Anti-lock Braking System (ABS) / 20
 Disc, Four-wheel / 13
 Brake Assist / 21
 Cargo Area
 Cargo Area / 16
 Cover, Privacy / 17
 Rear Cargo Management System / 16
 Child Safety Locks, Rear Door / 20
 Climate Control System / 16
 Colors, Exterior / 8, 9, 28
 Colors, Interior / 10, 28
 Console, Configurable Center / 16
 Construction, Unibody / 9, 13, 22
 Design Elements, Exterior / 8, 9
 Design Elements, Interior / 8, 10
 Engine
 3.5L Duratec® V6 / 11, 12
 Aggressive Deceleration Fuel Shut-off (ADFSO) / 12
 intake-Variable Cam Timing (i-VCT) / 12
 Environmental Features / 23
 Front-wheel Drive (FWD) / 11, 13
 Fuel Economy / 12, 30
 Grille, Tri-bar / 8, 9
 Ground Clearance / 9
 Lamps, Exterior
 Fog Lamps / 8, 9
 Headlamps, Automatic / 15
 Headlamps, Quad Beam / 9
 LATCH (Lower Anchors and Tethers for Children) System / 20, 22
 Liftgate, Power / 14, 15
 Lighting, Ambient Interior / 8

Navigation System, Voice-activated with SIRIUS Travel Link™ / 14, 18, 25
 NVH (Noise, Vibration and Harshness) / 23
 Packages
 Cargo Package / 17
 Convenience Package / 17
 Leather Comfort Package / 17
 Limited Interior Appearance Package / 17
 Navigation Package / 17
 SPORT Premium Package / 17
 Trailer Tow Package / 11, 13
 Panoramic Vista Roof™ / 8, 10, 23
 Personal Safety System™ / 20, 22
 Ratings, Crash Test / 20
 Remote Keyless Entry System with Integrated Keyhead Transmitters / 17
 Reverse Sensing System / 14, 15
 Roadside Assistance, 24-Hour / 22, 23
 Roof Side Rails, Factory-installed / 15
 Safety Canopy® System with Rollover Sensor / 20, 22
 Seating
 EasyFold™ Rear Seatback Release / 14, 16
 Seatback, Front Passenger Fold-flat / 15, 16, 28
 Seatbacks, Rear Fold-flat / 15, 16, 28
 SecuriCode™ Keyless Entry Keypad / 14
 SOS Post Crash Alert System / 20
 Spoiler, Rear / 8
 Steering Column, Tilt/Telescoping / 16
 Suspension
 Independent MacPherson Strut Front Suspension / 11, 13
 Independent Multi-link Rear Suspension / 11, 13
 SYNC® Voice-activated Communications and Entertainment System / 14, 18, 19
 Testing, Durability / 23
 Tire Pressure Monitoring System (TPMS) / 21
 Towing
 Capacity / 13
 Flat/Neutral / 13
 Traction Control / 20, 21
 Transmission, 6-speed Automatic / 11, 12, 30
 Warranty
 Powertrain Limited / 23
 Wheels, Aluminum / 8, 9, 27



WHAT'S NEW

This page is about:

- Model/Series/Availability
- Exterior Changes/Interior Changes
- Functional Changes
- Package Changes
- Key Competitors

2010 Edge

What's New

Overview

Key Messages

EDGE



- Edge offers a four-model lineup, including the SPORT with 20" chrome-clad wheels
- Bold design with the flexibility of an SUV and the luxurious style of a sedan
- The excitement of a crossover vehicle without sacrificing an energetic performance and a spirited, sport handling
- Voice-activated Navigation System with SIRIUS Travel Link™ includes a 10 GB Music Jukebox

Model/Series/Availability

- Four model lineup continues
 - SE (front-wheel drive only)
 - SEL
 - Limited
 - SPORT

Exterior Changes

- 20" premium chrome-clad aluminum wheels with SPORT center cap standard on Edge SPORT
- Colors added:
 - Ingot Silver Metallic (UX)
 - Red Candy Metallic with Tinted Clearcoat (U6)
 - Tuxedo Black Metallic (UH)
- Colors deleted:
 - Black
 - Brilliant Silver Metallic
 - Redfire Metallic

Interior Changes

- Camel cloth no longer offered on SEL

Functional Changes

- Trailer Tow Package not available on SE
- SYNC® now offers Traffic, Directions and Information capability (when paired with the Voice-activated Navigation System, SYNC Traffic, Directions and Information services are replaced by the vehicle's Navigation System and SIRIUS Travel Link functionality)

Package Changes

- Limited Interior Appearance Package includes:
 - Unique Sienna leather-trimmed seats with accent stitching
 - Accent stitching on leather-wrapped steering wheel and shifter handle
 - Dark brushed-aluminum center stack appliqué
 - Premium floor mats with "Edge" logo
- Blue Suede Interior Appearance Package no longer offered

Key Competitors

- **Nissan Murano** offers trendy styling and a V6 engine with 265 horsepower and CVT (continuously variable transmission)
- **Honda Pilot** was redesigned for the 2009 model year and continues to offer traditional SUV styling and capability. The 3.5L V6 engine with Variable Cylinder Management delivers an average 250 horsepower and is mated to a 5-speed automatic transmission. The primary Pilot advantage is seating for 8
- **Toyota Venza** was all-new for the 2009 model year. Toyota claims Venza will raise the crossover vehicle to new levels by combining a unique blend of sedan refinement and sport utility vehicle (SUV) functionality. Key features include a standard 2.7L I-4 or optional 268-horsepower 3.5L V6 engine, a Toyota-first available panoramic roof and seating for five

NOTE: See the latest Dealer Ordering Guide for feature availability.

2010 Edge

What's Important

WHAT'S IMPORTANT

This page is about:

Product Highlights

Product Highlights

KEY EDGE FEATURES

3.5L Duratec® V6 engine and 6-speed automatic transmission

(pgs. 11, 12)

Panoramic Vista Roof™

(pgs. 8, 10, 23)

Available

All-Wheel Drive (AWD)

(pgs. 11, 13, 20, 21)



Voice-activated Navigation System

(pgs. 14, 18, 25)

AdvanceTrac® with RSC® (Roll Stability Control™)

(pgs. 20, 21)

Bold design and flexibility

(pgs. 8, 9, 10, 15, 16, 17)

Design/Styling

- SPORT model
- Limited Interior Appearance Package
- Panoramic Vista Roof™ with dual power sunshades
- Bold chrome tri-bar grille
- Quad beam design headlamps
- Fog lamps with chrome bezel
- Rear spoiler
- Dual chrome-rolled exhaust tips
- Ambient interior lighting
- Textured aluminum and chrome interior accents
- Contrasting stitching on leather-trimmed seats
- Large 20" and 22" wheel designs
- Ample ground clearance

Performance/Handling

- 3.5L Duratec® V6 engine with 265 horsepower and 250 lb.-ft. of torque
- 6-speed automatic transmission
- Sporty, agile and responsive handling
- Front-wheel drive (FWD) or available All-Wheel Drive (AWD) drivetrain
- Independent MacPherson strut front suspension and independent multi-link rear suspension
- EPA-estimated fuel economy
 - FWD (city/hwy.) 18/25
 - AWD (city/hwy.) 17/23
- 3500-lb. towing capacity when properly equipped

Comfort/Convenience

- Power liftgate
- Auxiliary audio input jack
- Power points — (4) 12-volt
- SIRIUS® Satellite Radio
- SYNC® voice-activated communications and entertainment system
- 6-disc in-dash CD player
- Voice-activated Navigation System with SIRIUS Travel Link™
- Tilt/telescoping steering column
- Fold-flat front passenger seatback
- EasyFold™ rear seatback release
- Configurable center console
- 6 total cup holders
- Rear cargo management system
- Remote Keyless Entry with two integrated keyhead transmitters
- Reverse Sensing System
- SecuriCode™ Keyless Entry Keypad

Safety/Security

- IIHS Top Safety Pick⁽¹⁾
- AdvanceTrac® with RSC® (Roll Stability Control™)
- Anti-lock Braking System (ABS)
- Safety Canopy® System with rollover sensor
- Front-seat side airbags
- Personal Safety System™
- LATCH child safety seat system
- SOS Post Crash Alert System
- SecuriLock® passive anti-theft system
- Tire Pressure Monitoring System (TPMS)

Quality/Reliability/Durability

- Low levels of NVH (Noise, Vibration and Harshness)
- Computer-controlled shift quality
- Exceptionally efficient and clean operating engine
- 5-year/60,000-mile Powertrain Limited Warranty and Roadside Assistance Program

(1) Based on 2009 ratings. 2010 testing information not available at time of print. Please visit IIHS.org for additional information.

NOTE: See the latest Dealer Ordering Guide for feature availability.

MODEL LINEUP

This page is about:

SE

2010 Edge Model Lineup

Model Lineup Pages

The Model Lineup pages are based on the Dealer Ordering Guide and are designed to show key features/equipment on each model as well as Rapid Spec content. As you move through the model lineup, each model adds to or upgrades the equipment of the preceding model, except where additions/exemptions are noted. The Edge is available in four models:

- SE
- SEL
- Limited
- SPORT

SE — Standard model



Performance/Handling

- Axle ratio — 3.16:1 for all models
- Brakes — Four-wheel Anti-Lock Braking System (ABS)
- Drivetrain — front-wheel drive (FWD)
- Engine — 3.5L Duratec® V6 engine
- Fuel tank
 - 19.2-gallon (FWD)
 - 20.8-gallon (AWD)
- Independent MacPherson strut front suspension and independent multi-link rear suspension
- Power rack-and-pinion steering
- Spare tire — mini
- Tires — P235/65R17 all-season
- Transmission — 6-speed automatic

Design/Styling

- Antenna — roof mounted
- Chrome 3-bar grille
- Dual chrome-rolled exhaust tips
- Exterior door handles — black
- Exterior mirrors — black
- Headlamps — quad beam halogen
- Interior door handles — chrome
- Rear spoiler — black
- Rocker moldings — black
- Wheels — 17" painted aluminum

Comfort/Convenience

- 12V power points (4 total)
- Accessory delay
- Audio
 - Single CD player/MP3 with 4 speakers
 - Auxiliary audio input jack
- Battery Saver
- Cargo area light
- Center console gear shifter with urethane shift knob and chrome bezel
- Climate control
 - Single-zone manual air conditioning
 - 2nd-row heat and AC vents

- Coat hooks (2)
- Cruise control
- Cup holders/bottle holders (6)
- Defroster — rear window
- Dome map lamps — 1st and 2nd rows
- Door locks — power with autolock
- Exterior mirrors — manual folding, power side with integrated blind spot mirrors
- Front and rear floor mats
- Front console with deep bin, 2 cup holders and 1 power point
- Glass
 - Privacy glass on rear door, quarter windows and back window
 - Solar-tinted driver/passenger windows
- Glove box — non-locking
- Grab handles (2) — front-passenger and 2nd-row B-pillar
- Horn — dual-tone electric
- Instrumentation — includes tachometer, lamp outage, low fuel warning, low washer fluid, low oil pressure, door ajar, liftgate ajar and coolant temperature indicator
- Map pockets
 - Front seatback
 - In 4 door panels
 - Bottle holders in front door panels
- Overhead console with sunglasses holder
- Rear armrest with 2 cup holders
- Rear cargo area tie downs, hooks and net
- Rear wiper — dual-speed
- Remote Keyless Entry with integrated keyhead transmitter (2)
- Seats
 - 1st-row cloth bucket seats
 - 2nd-row cloth 60/40 fold-flat bench
 - Driver manual lumbar
 - Rear-seat manual recline
- Steering column — tilt/telescoping, manual
- Steering wheel — urethane with cruise control
- Sun visors — dual
- Windows — power with driver one-touch up/down and front/rear disable
- Windshield wipers — intermittent speed sensitive

Safety/Security

- Adjustable head restraints
- AdvanceTrac® with RSC® (Roll Stability Control™)
- Autolock
- Belt-Minder® System (driver and front passenger)
- Child safety locks — rear door
- Front Passenger Sensing System
- Height-adjustable safety belts (front row)
- Illuminated Entry System
- LATCH child safety seat system (2) in second row
- Personal Safety System™ with dual-stage front airbags
- Safety Canopy® System with rollover sensor for two rows of protection
- Securilock® passive anti-theft system
- Side airbags — front seats
- SOS Post Crash Alert System
- Tire Pressure Monitoring System (TPMS)

EDGE SE RAPID SPEC OPTIONS

Rapid Spec

Option Group 100A

- Includes SE standard equipment

Option Group 101A

- Convenience Package
 - Electrochromic auto-dimming rearview mirror
 - Autolamp automatic on/off headlamps
 - SecuriCode™ Keyless Entry Keypad — black
 - Redundant audio controls
 - Reverse Sensing System
- SIRIUS® Satellite Radio

Freestanding Options

Performance/Handling

- All-Wheel Drive (Fleet only)

Comfort/Convenience

- All-weather floor mats
- SYNC® voice-activated communications and entertainment system (101A only)

Design/Styling

- Front license plate bracket
- Red Candy Metallic with tinted clearcoat exterior paint
- Roof rack

NOTE: The above information is an excerpt to be used with page 1 of the 5/15/09 Edge Dealer Ordering Guide. For the latest Dealer Ordering Guide go to fmcdealer.com.

2010 Edge

Model Lineup

MODEL LINEUP

This page is about:

SEL —

SEL — All SE content, plus:



Design/Styling

- Body-color, painted door handles, side mirrors and rear spoiler
- Exterior mirror caps — body-color
- Fog lamps with chrome bezel
- Rear spoiler — painted body-color
- SEL badge
- Unique aluminum instrument panel finish
- Unique chrome interior treatments
- Wheels — 18" Premium painted aluminum

Comfort/Convenience

- Audio — Premium Sound System I with 6-disc in-dash CD/MP3 player and 4 speakers (single CD with Navigation system)
- Dual illuminated visor mirrors
- Electrochromic auto-dimming rearview mirror
- Leather steering wheel and shifter covers
- Message Center with compass
- Reverse Sensing System
- Seats
 - 1st- and 2nd-row unique cloth seats
 - 6-way power driver's seat with recline and manual lumbar support
- Second Row EasyFold™ remote seat release
- SecuriCode™ Keyless Entry Keypad — black
- SIRIUS® Satellite Radio
- Steering wheel with redundant audio controls

EDGE SEL RAPID SPEC OPTIONS

Rapid Spec

Option Group 200A

- Includes SEL standard equipment

Option Group 201A

- SYNC® voice-activated communications and entertainment system
- 18" Chrome-clad wheel (includes P245/60R18 all-season tire)

Option Group 202A

Includes Option Group 201A, plus:

- Leather Comfort Package
 - 6-way power passenger seating
 - Dual-zone Electronic Automatic Temperature Control with cabin particulate air filter
 - Front passenger fold-flat seatback
 - Heated front seats
 - Leather-trimmed seats
- Ambient interior lighting

Freestanding Options

Performance/Handling

- All-Wheel Drive
- Trailer Tow Package

Comfort/Convenience

- All-weather floor mats
- Cargo Package (201A and 202A only)
 - Rear Cargo Management System
 - Power liftgate
- Navigation Package (202A only)
 - Premium audio system with 9 speakers
 - Voice-activated Navigation System with SIRIUS Travel Link™
- Panoramic Vista Roof™ (201A and 202A only)
- SYNC® voice-activated communications and entertainment system (200A only)

Design/Styling

- Front license plate bracket
- Red Candy Metallic with tinted clearcoat exterior paint
- Roof rack (not available with Panoramic Vista Roof)
- White Platinum Metallic Tri-coat exterior paint

Edge

NOTE: The above information is an excerpt to be used with page 5 of the 5/15/09 Edge Dealer Ordering Guide. For the latest Dealer Ordering Guide go to fmcdealer.com.

May 2009

esourcebook.dealerconnection.com

MODEL LINEUP**This page is about:**

— Limited

2010 Edge Model Lineup

Limited — All SEL content, plus:**Design/Styling**

- Ambient interior lighting
- Beltline molding — chrome
- Limited badge
- SecuriCode™ Keyless Entry Keypad — body-color
- Wheels — 18" chrome-clad includes 18" P245/60R18 all-season tire

Comfort/Convenience

- Audio — Premium Sound System with 9 speakers
- Climate control — Dual-zone Electronic Automatic Temperature Control
- Mirrors, exterior — heated, with security approach lamps and memory
- Particulate air filter
- Seats
 - 1st- and 2nd-row leather-trimmed seats
 - Fold-flat front passenger seatback
 - Heated front seats
 - Memory driver's seat
- SYNC® voice-activated communications and entertainment system
- Unique brushed aluminum center stack finish panel and door sill plates
- Unique grey metallic-faced gauges
- Universal garage door opener

EDGE LIMITED RAPID SPEC OPTIONS**Rapid Spec****Option Group 300A**

- Includes Limited standard equipment

Option Group 301A

- Panoramic Vista Roof™
- 20" Chrome-clad wheel (includes P245/50R20 all-season tire)

Option Group 302A

Includes Option Group 301A, plus:

- Cargo Package
 - Rear Cargo Management System
 - Power liftgate
- Voice-activated Navigation System with SIRIUS Travel Link™

Freestanding Options**Performance/Handling**

- All-Wheel Drive
- Trailer Tow Package

Comfort/Convenience

- All-weather floor mats
- Cargo Package (300A and 301A)
- Panoramic Vista Roof™ (300A only)
- Roof rack (300A only; not available with Vista Roof)
- Voice-activated Navigation System with SIRIUS Travel Link™ (300A; included in 302A)

Design/Styling

- Front license plate bracket
- Red Candy Metallic with tinted clearcoat exterior paint
- White Platinum Metallic Tri-coat exterior paint
- Limited Interior Appearance Package
 - Accent stitching on leather-wrapped steering wheel and shifter handle
 - Dark brushed aluminum center stack appliqué
 - Premium floor mats with "Edge" logo
 - Unique Sienna leather seat face with contrast stitching

NOTE: The above information is an excerpt to be used with page 1 of the 5/15/09 Edge Dealer Ordering Guide. For the latest Dealer Ordering Guide go to fmcdealer.com.

2010 Edge Model Lineup

MODEL LINEUP

This page is about:

SPORT

SPORT — All SEL content, plus:



Performance/Handling

- Tires — P245/50R20 all-season

Design/Styling

- 20" chrome-clad aluminum wheels with SPORT center caps
- Body-color door cladding and side skirt rocker moldings
- Body-color front and rear lower fascias
- Brake dust shield
- Exterior colors limited to:
 - Ingot Silver Metallic
 - Red Candy Metallic with tinted clearcoat exterior paint
 - Sport Blue Metallic
 - Tuxedo Black Metallic
- Larger diameter bright exhaust tips
- SPORT badge on liftgate
- Unique blacked out headlamp and taillamp treatment

Comfort/Convenience

- Ambient interior lighting
- Cargo Management System
- Leather-wrapped steering wheel and shift handle with contrast stitching
- Seating
 - Leather-trimmed 1st- or 2nd-row seating with Grey Alcantara® seat inserts
 - EasyFold™ rear seatback release
- SYNC® voice-activated communications and entertainment system
- Unique dark brushed instrument panel center stack

EDGE SPORT RAPID SPEC OPTIONS

Rapid Spec

Option Group 400A

- Includes SPORT standard equipment

Option Group 401A

- Premium Package
 - Heated front seats
 - Dual-zone Electronic Automatic Temperature Control with cabin particulate air filter
 - Front passenger fold-flat seatback
 - 6-way power passenger seat
 - Memory driver's seat
 - Memory and heated mirrors with security approach lamps
 - Universal garage door opener
 - Power liftgate

Freestanding Options

Performance/Handling

- All-Wheel Drive
- 22" Bright polished aluminum wheel (includes sport-tuned suspension and P265/40R22 all-season tires)

Comfort/Convenience

- All-weather floor mats
- Navigation Package (401A only)
 - Voice-activated Navigation System with SIRIUS Travel Link™
 - Premium audio system with 9 speakers

Design/Styling

- Front license plate bracket
- Red Candy Metallic with tinted clearcoat exterior paint

Edge

NOTE: The above information is an excerpt to be used with page 1 of the 5/15/09 Edge Dealer Ordering Guide. For the latest Dealer Ordering Guide go to fmcdealer.com.

May 2009

2010 Edge

Design/Styling

This page is about:

- Edge SPORT Model
- Wheel Designs
- Panoramic Vista Roof™
- Rear Spoiler
- Bold Tri-bar Chrome Grille
- Ambient Interior Lighting

Overview

Key Messages

EDGE

- Edge SPORT model with unique exterior and interior design/styling features
- Bold American design theme with a sporty, muscular stance and strong interior design elements
- Aluminum wheel designs available in 17", 18", 20" and 22" sizes

Key Features

Edge SPORT Model

Edge SPORT offers unique exterior design and styling elements, including:

- Body-color front and rear lower fascias, door cladding and rocker moldings
- Lower front valance with integrated fog lamps and chin spoiler
- Blacked out headlamp and taillamp treatments
- 3.5" polished exhaust tips
- 20" chrome-clad aluminum wheels with SPORT center caps
- Optional 22" bright polished aluminum wheels with SPORT center caps
- Sport-tuned suspension
- Exterior colors limited to:
 - Ingot Silver Metallic
 - Red Candy Metallic with Tinted Clearcoat
 - Sport Blue Metallic
 - Tuxedo Black Metallic

Edge SPORT unique interior features include:

- Grey Alcantara® seat inserts contrasted with charcoal black trim
- Leather-wrapped shift handle with contrast stitching
- Unique dark brushed aluminum center stack appliqué



Exterior Design Elements

Wheel designs include 20" and 22" aluminum wheels.

Panoramic Vista Roof™ brightens the interior and gives front-seat passengers a power moonroof and second-row passengers their own personal skylight.

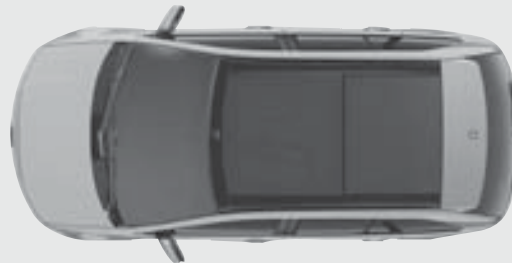

Rear spoiler gives an aerodynamic, sporty look.

Bold tri-bar chrome grille is distinctly Ford.



Interior Design Elements

Ambient interior lighting

- LED (Light-Emitting Diode) lights illuminate the front and rear footwells and cup holders with a soft, colorful glow
- Seven different color choices include aqua, blue, green, purple, red, white and yellow

2010 Edge

Design/Styling

DESIGN/STYLING

This page is about:

- Stylish Wraparound Tri-bar Chrome Grille
- Quad Beam Headlamps
- Distinctive Fog Lamps
- Power Dome Hood
- Aluminum Wheels
- Exterior Colors

Exterior Design Elements

Stylish wraparound tri-bar chrome grille flows into the headlamps.

Quad beam headlamps make a strong first impression.

Distinctive fog lamps with chrome bezels give a sporty appearance to the front end and provide added light to improve vision during night driving in poor weather.

Large blue oval positioned prominently in the center of the tri-bar chrome grille.

Power dome hood hints at the powerful Duratec® 3.5L engine below.

Raised beltline and strong sculpted shoulders around the wheel arches emphasize Edge's power and performance.

Wide, aggressive stance with wheels planted at the extreme corners, giving Edge good interior room and a powerful appearance.

Ample ground clearance is useful for light off-roading and gives drivers and passengers a commanding view of the road.

Sharp graphic lines and fast angles define Edge's athletic character.

Matte black lower fascia and rocker panels enhance the powerful stance. Body color on SPORT.

Dual chrome-rolled exhaust tips lend a sporty, aggressive appearance.

Feeling of motion comes from the fast-raked windshield, fast-sloping back window with high-mounted rear spoiler.

Unibody construction delivers smooth ride and sporty handling with ample ground clearance and cargo flexibility.

Aluminum Wheels

- 17" painted
- 18" painted
- 18" chrome-clad
- 20" chrome-clad
- 20" chrome-clad with SPORT center cap
- 22" bright polished with SPORT center cap
- See page 27 for availability

Exterior Colors

- New Ingot Silver Metallic
- New Red Candy Metallic with tinted clearcoat
- New Tuxedo Black Metallic
- Cinnamon Metallic
- Dark Ink Blue Metallic
- Sport Blue Metallic
- Sterling Grey Metallic
- White Platinum Metallic Tri-coat
- White Suede
- See page 28 for availability and order codes



This page is about:

- Illuminated Controls
- Center Stack
- Leather-wrapped Steering Wheel
- Precision Fit
- Interior Colors
- Panoramic Vista Roof™

Interior Design Elements

“Cockpit” design adds a sporty feel.

Textured aluminum accents on instrument panel and center console add elegance.

Chrome-clad instrument cluster and floor-mounted shifter.

Panoramic Vista Roof™ with dual power sunshades for wide-open-air driving enjoyment.

Contrasting color-thread stitching on leather-trimmed seats was inspired by the fashion industry.

Two-tone door panels add depth and interest.

Illuminated controls on steering wheel make it easy to find the controls at night.

Center stack flows into center console with floor-mounted shifter for a performance feel.

Leather-wrapped steering wheel and shifter handle on SEL, SPORT and Limited.

Precision fit of instrument panel looks like it was fashioned out of one piece.

Unique interior treatments with the available Limited Interior Appearance Package include Sienna leather-trimmed seats, contrast stitching on the steering wheel and shifter handle, dark brushed aluminum center stack appliqué and floor mats with the “Edge” logo.

Interior Colors include:

- Camel
- Charcoal Black
- Medium Light Stone



Panoramic Vista Roof™

- Brightens the interior and gives front-seat passengers a power moonroof and second-row passengers their own personal skylight
- **Two large glass panels** come together to form the roof, encompassing almost the entire roof area
- **Movable front glass panel**
 - 10.07 sq. ft. of glass area
 - One-touch feature opens panel to a vent position
 - Push the button a second time for fully opened position
 - Provides 676 sq. in. of maximum total air opening
- **Fixed rear glass panel**
 - 8.04 sq. ft. of glass area
 - Provides an enormous skylight for natural light to flood the interior when the front panel is closed
- **Daylight Opening (DLO)** is over three times larger than the average traditional moonroof
 - Front and rear panel combined DLO is 1295 sq. in.
 - Average traditional moonroof DLO is 407 sq. in.
- **Dual power sunshades** provide approximately 100 percent sun blockage and are designed to help keep the cabin cool and protect passengers and interior materials from UV rays
- **Most analyzed/tested moonroof in Ford Motor Company history** provides a leak-free open-air design without sacrificing interior quietness
 - Designed to maintain reduced wind noise for interior quietness
 - Utilizes the thickest (5mm) available roof glass in Ford Motor Company history
 - Vista Roof is designed to prevent leakage in a heavy downpour, even in the vent position
 - Design is capable of managing 1.2 gallons of water per minute at a 15 percent incline with all the water channeled to one corner of the roof



2010 Edge

Performance/Handling

PERFORMANCE/HANDLING

This page is about:

- 3.5L Duratec® DOHC V6 Engine
- 6-speed Automatic Transmission
- All-Wheel Drive (AWD)
- Independent MacPherson Strut Front Suspension
- Independent Multi-link Rear Suspension
- Towing

Overview

Key Messages

EDGE



- 265-horsepower 3.5L Duratec® V6 engine and 6-speed automatic transmission
- Multi-link independent rear suspension
- Available with front-wheel drive or All-Wheel Drive (AWD) drivetrain

Key Features

Powertrain

3.5L Duratec DOHC V6 engine combines durability and efficiency to deliver 265 horsepower and 250 lb.-ft. of torque.

6-speed automatic transmission provides smooth, quiet operation. Paired with the 3.5L Duratec DOHC V6 engine, this powertrain delivers impressive off-the-line acceleration and fuel economy.

All-Wheel Drive (AWD) uses an electromagnetic activation of an internal clutch pack to provide all-weather traction and is a feature not found on some competitors.

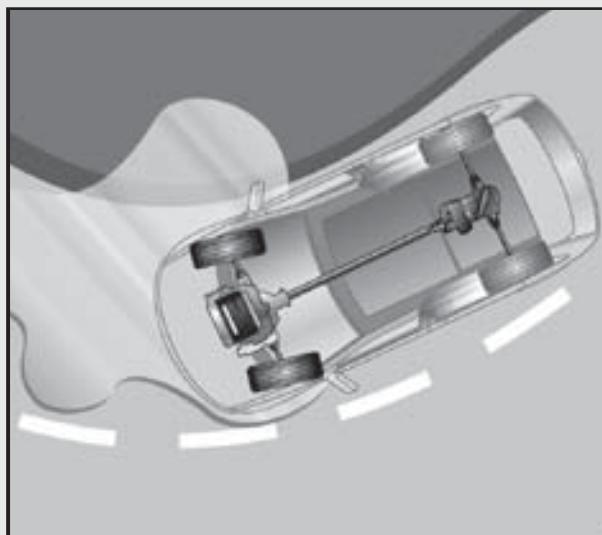
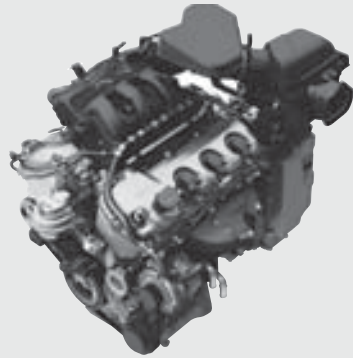

Chassis

Independent MacPherson strut front suspension uses friction-reducing geometry for precise tuning of the shock absorber valves for remarkable ride and handling.

Independent multi-link rear suspension is built on a robust fully boxed subframe. The shock absorbers are mounted as far outboard as possible — allowing chassis engineers to tune them to handle higher road impacts and deliver an excellent balance of ride and handling.

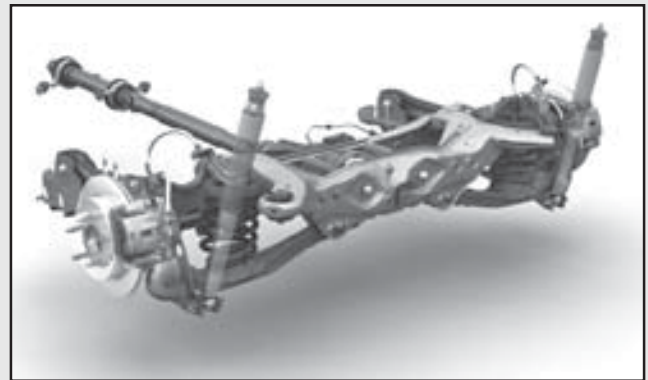

Edge SPORT includes a revised chassis for enthusiasts with specifically tuned springs, shocks, and struts, plus a sport-tuned steering ratio. The final drive ratio increases to 3.39:1 when equipped with available AWD, and if the SPORT has the available 22" wheels, it gets a sport-tuned suspension with larger stabilizer bars.

Towing

3,500-lb. maximum towing capacity on models equipped with the Trailer Tow Package.

2010 Edge

Performance/Handling

This page is about:

- 3.5L Duratec® DOHC V6 Engine
- intake-Variable Cam Timing (i-VCT)
- 6-speed Automatic Transmission
- Powertrain Performance Benefits
- EPA-estimated Fuel Economy

Powertrain

3.5L Duratec® DOHC V6 Engine

- 265 horsepower @ 6250 rpm
- 250 lb.-ft. of torque @ 4500 rpm
- Aggressive Deceleration Fuel Shut-off (ADFSO) technology helps maximize fuel economy
- No premium fuel required. 87-octane fuel helps keep operating costs low
- Strong, lightweight die cast aluminum block
- Lightweight 4-valves-per-cylinder heads improve performance
- 10.3:1 compression ratio helps improve power and fuel economy while still meeting Federal Tier 2 Bin 5 or California Ultra Low Emissions Vehicle (ULEV II) standards
- Electronic throttle body uses an accelerator pedal sensor to read and interpret the driver's intentions
- Intake was designed as a system, all the way from air inlet to the intake valves, to create optimum flow for peak power and to broaden the torque curve
- Forged steel, fully counterweighted crankshaft
- High-temperature alloy, cast aluminum pistons with low-friction coating

intake-Variable Cam Timing (i-VCT)

- Allows the camshafts to operate the intake valves at different times in the combustion cycle, based on speed and load
- Adjusts cam timing to provide optimum performance and fuel economy
- Outstanding efficiency under low load conditions like idling or highway cruising
- Remarkable power when accelerating

6-speed Automatic Transmission

- Wide 6.04:1 gear ratio delivers good fuel economy and performance
- Short first and second gears provide impressive launch and acceleration
- Tall overdrive gear is designed to provide better fuel economy
- Short steps between intermediate gears enhance performance and feel by finding the right gear for the most efficient operating conditions
- Every part of the transmission is designed to provide smooth, quiet operation
- Transmission fluid "filled for life" to help lower cost of ownership

Powertrain Performance Benefits

- Mating the 3.5L Duratec V6 engine to a 6-speed automatic transmission helps optimize performance
- Closely spaced gears of the 6-speed transmission allow the engine to always find its "sweet spot" — the gear that maximizes engine power
- Quick, responsive acceleration

EPA-estimated Fuel Economy

- FWD (city/hwy.) — 18/25
- AWD (city/hwy.) — 17/23

ENGINEERING INSIGHT

Aggressive Deceleration Fuel Shut-off (ADFSO)

- Helps maximize fuel economy
- Temporarily interrupts fuel delivery and consumption when the vehicle normally slows down while maintaining normal engine operation
- System uses the transmission to keep the engine running at a low, more fuel-efficient operating level whenever possible
- Normal fuel delivery resumes when the vehicle reaches a low speed or when the driver accelerates
- Excellent drivability is maintained by Ford-proprietary software that integrates this technology with the 3.5L V6 powertrain operation
- System is automatic and requires no interaction from the driver



2010 Edge

Performance/Handling

PERFORMANCE/HANDLING

This page is about:

- Components Working Together
- Front-wheel Drive (FWD)
- Available All-Wheel Drive (AWD)
- Front and Rear Suspensions
- Four-wheel Disc Brakes
- Towing Capacity

Chassis

Components Working Together

- Four-wheel independent suspension delivers responsive sports-sedan-like handling
- Suspension tuning helps hug the road when cornering
- Braking feels confident and smooth
- Unibody construction with front and rear subframes helps isolate the body from the suspension

Front-wheel Drive (FWD)

- Weight of engine on front end provides good traction in slippery road conditions
- Allows for a roomy interior package, especially rear-seat leg and foot room

Available All-Wheel Drive (AWD)

- Uses an electromagnetic activation of an internal clutch pack to provide all-weather traction and is a feature not found on some competitors
- AWD is seamless to the driver and provides performance as well as safety benefits
- Continuously monitors vehicle speed, throttle input, steering angle and wheel slip to seamlessly deliver torque to the appropriate wheel
- Helps eliminate torque steer and helps balance the vehicle when cornering
- In a curve, the front wheels steer the vehicle to maintain direction, as well as propel the vehicle forward
- AWD system sends power to the rear wheels, allowing the rear wheels to help propel the vehicle
- This helps improve overall handling by allowing the front tires to apply more available traction to steer the vehicle
- For the safety benefits of AWD, see page 21

Independent MacPherson Strut Front Suspension

- Uses friction-reducing geometry for precise tuning of the shock absorber valves for remarkable ride and handling
- Rear-facing L-arms
- Stamped-steel clamshell design lower control arms
- Cast iron knuckles and stabilizer bar
- Isolated perimeter subframe is firmly attached in 6 locations for added strength and stiffness
- Hydro bushings are tuned to isolate brake and road vibrations

Independent Multi-link Rear Suspension

- Built on a robust fully boxed frame
- Stamped-steel control blades improve suspension tuning
- Vertically oriented shocks mounted outboard and behind the wheel center for improved ride and handling

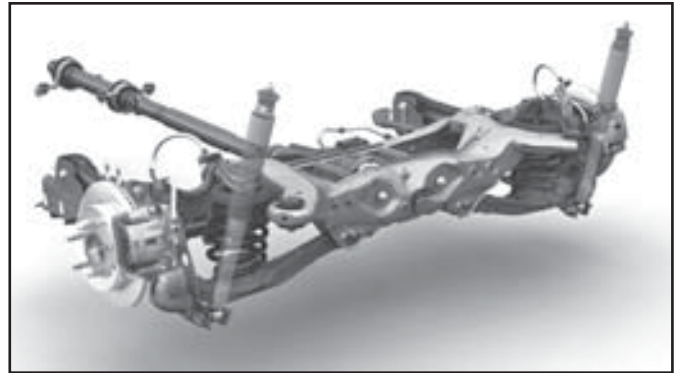

Four-wheel Disc Brakes

- Large diameter front and rear rotors provide impressive stopping power
- Low dust generation results in cleaner wheels and helps slow wheel deterioration
- Confident brake feel
- Standard on all models

Towing Capacity

- Standard towing capacity of 2000 lbs.
- Maximum towing capacity of 3500 lbs. on models equipped with the optional Trailer Tow Package
- Trailer Tow Package includes:
 - Class II receiver hitch
 - Larger radiator
 - Upgraded cooling fans
 - Wiring harness with 4-pin connector
 - Available on SEL and Limited

Flat/Neutral Towing

Also known as four-wheel-down towing, it refers to towing a vehicle with all four of its wheels on the ground — for example, when towing a vehicle behind a motorhome. All Edge models can be neutral-towed. ONLY Edge FWD models can be dolly towed (front wheels off the ground). NEVER dolly tow an Edge with AWD. See Owner's Guide for complete details.

COMFORT/CONVENIENCE

This page is about:

- Blind Spot Exterior Mirrors
- Reverse Sensing System
- EasyFold™ Seat
- Voice-activated Navigation System with SIRIUS Travel Link™
- SYNC®
- Edge SPORT Model

2010 Edge

Comfort/Convenience

Overview

Key Messages

EDGE



- Edge SPORT model
- Comfortable seating for 5 passengers
- Blind spot exterior mirrors help keep drivers aware of vehicles entering their “blind zone”
- SYNC® voice-activated communications and entertainment system includes Traffic, Directions and Information functionality for 2010

Key Features

Exterior

Blind spot exterior mirrors help keep the driver aware of vehicles entering their “blind zone” by integrating a secondary convex mirror into the traditional exterior sideview mirror design.

Reverse Sensing System sounds audible warning tones through the audio system when an object is detected behind the vehicle.

Power liftgate can be opened or closed with a press of a button on the integrated keyhead transmitter or instrument panel.

Industry-exclusive SecuriCode™ Keyless Entry Keypad lets the driver lock/unlock the doors and open the liftgate by simply using the numbered keypad on the driver’s-door B-pillar.

Seating

EasyFold™ seat drops either rear seatback at the touch of a button for easy cargo loading or folds flat to provide a level cargo area loadfloor.



Interior

Voice-activated Navigation System with SIRIUS Travel Link™ includes a Music Jukebox and an easy-to-use LCD touch screen. SIRIUS Travel Link provides access to real-time traffic and weather updates, sports updates, and movie listing information.⁽¹⁾

SYNC voice-activated communications and entertainment system⁽²⁾ now includes Traffic, Directions and Information functionality for 2010. This latest version of SYNC provides access to turn-by-turn directions, personalized traffic reports and business search (411) — all accessed by voice commands — in addition to 911 Assist™ and Vehicle Health Report (VHR) functionality. See pages 18 and 19 for feature descriptions and restrictions.

Edge SPORT model includes these key comfort/convenience elements:

- Grey Alcantara® seat inserts contrasted with charcoal black leather-trimmed seats and steering wheel
- Leather-wrapped shift handle with contrast stitching
- Cargo Management System
- Unique dark brushed aluminum center stack appliqué



(1) Real-time traffic monitoring available in select markets. Some features are unavailable while driving. Service available in the 48 contiguous states and Washington, D.C. SIRIUS Travel Link is a trademark of SIRIUS XM Radio, Inc.

(2) Driving while distracted can result in loss of vehicle control. Only use mobile phones and other devices, even with voice commands, when it's safe to do so.

2010 Edge

Comfort/Convenience

COMFORT/CONVENIENCE

This page is about:

Factory-installed Roof Side Rails	—
Power Liftgate	—
Blind Spot Exterior Mirrors	—
Reverse Sensing System	—
Automatic Headlamps with Wiper Activation	—
Seating	—

Exterior

Factory-installed Roof Side Rails

Optional factory-installed roof side rails offer a sporty appearance (not available on SPORT or models with a Vista Roof™). To make the side rails more functional, add the Genuine Ford Accessories optional dealer-installed cross rails. The roof rack can carry up to 100 lbs.

Points to remember about the dealer-installed cross rails:

- Cross rails are in a permanent, fixed position and bolted to the side rail for stability
- Cross rails are designed to accept aftermarket attachments for bike racks, etc.
- Cross rails have a low profile when attached to the side rail (the cross rail is hidden from view by the side rail)
- There are tie loops on each of the stanchions
- Bungee cords or ropes can be used to fasten items to the carrier

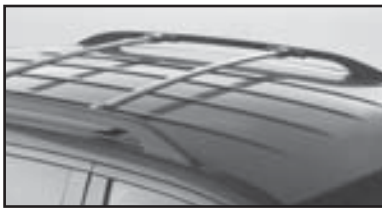

Power Liftgate

- Open or close the liftgate with the touch of a button on the instrument panel or on the integrated keyhead transmitter
- Liftgate can also be opened by the button under the liftgate handle and closed by the button inside the cargo area
- Provides functionality and convenience by making it easier to load and unload cargo
- Message Center includes a liftgate enable/disable function
- For additional safety, the liftgate will reverse the opening or closing motion if an obstacle is detected

Blind Spot Exterior Mirrors

- Help keep the driver aware of vehicles entering their “blind zone”
- Include an integrated secondary convex mirror into the traditional exterior sideview mirror design to provide an optimized field of view for the driver’s “blind zone”



Reverse Sensing System

- Alerts the driver with an audible tone to certain objects up to 6 feet behind the vehicle when backing up slowly
- Audible tone increases in frequency as vehicle nears an object until it becomes a continuous tone when the vehicle is less than 10 inches from the object
- Helps make parallel parking easier
- System is activated through four ultrasonic sensors located in the rear bumper

Automatic Headlamps with Wiper Activation

- Automatically activates the headlamps and taillamps if the wipers are being used — helping the driver see — and the vehicle be seen in inclement weather
- When the headlamp switch is in auto position, and the front wipers are activated in any mode except mist or wash, the vehicle headlamps will automatically turn on within 3 seconds
- Once the front wipers are deactivated, the headlamps will automatically turn off within 30 seconds

Seating

- Carries 5 adult passengers comfortably
- Available fold-flat front passenger seatback folds flat with single-handed operation for ease of use
- 60/40 split-folding rear seatbacks
- Up to 15-degree manual recline on rear seatbacks
- Unique cloth on SE and SEL
- Leather-trimmed seats standard on Limited and optional on SEL
- Leather-trimmed seats with grey Alcantara® inserts and contrast stitching on SPORT
- 6-way power driver seat with manual driver lumbar on SEL
- 6-way power passenger seat with recline and manual lumbar and fold-flat front passenger seat on Limited
- 6 cup holders (4 in front seat area, 2 in rear seat center armrest)
- Heated front seats included with Leather Comfort Package on SEL
- Heated front seats with memory driver’s seat standard on Limited
- Center second-row head restraint can be dropped out of sight for better rear visibility when not in use
- Map pockets on back of front seats

2010 Edge

Comfort/Convenience

This page is about:

- EasyFold™ Rear Seatback Release
- Configurable Center Console
- Cargo Area
- Climate Control System
- Tilt/Telescoping Steering Column
- Power Windows

Interior

EasyFold™ Rear Seatback Release

- Electromechanical seatback release switch (a first for Ford) drops either rear seatback at the touch of a button for easy cargo loading
- 60/40 split rear seatbacks are able to recline 15 degrees for rear-passenger comfort
- Rear seatbacks fold flat, creating a level loadfloor
- Integrated second-row center head restraint can be dropped out of sight when not in use for better visibility
- There are also 2 cup holders in the rear center armrest

Configurable Center Console

- This center console is a big selling point that sets Edge apart from the competition
- Removable divider and tray that organize space vertically and horizontally
- 12 different configurations
- Valuable items can be kept hidden from sight
- Holds a variety of laptops
- Holds CDs
- Concealed power point
- Auxiliary audio input jack for portable MP3 players
- Small slots molded into side of console help keep phone and MP3 cords neat and organized
- Console lid has a ticket clip, two pen holders and tissue holder

Cargo Area

- Large liftgate opening provides low-lift height to the cargo area
- 32.2 cubic feet of cargo space behind the rear seats offers plenty of space for 5 passengers, plus their suitcases and gear for a weekend getaway
- 69.0 cubic feet of cargo space with the rear seatbacks folded
- 8 feet of storage from front to rear with fold-flat front passenger and rear seatbacks folded down — long enough to bring home that antique grandfather clock



Climate Control System

- Large vents provide better air distribution, decreasing the number of hot/cold spots with the air conditioning on
- Stays cooler when idling with air conditioning on
- Dual-zone Electronic Automatic Temperature Control allows the driver and front passenger to choose their own temperature setting

Tilt/Telescoping Steering Column

- Provides a comfortable driving position for drivers of different sizes

Power Windows

- Driver's window has one-touch power up/down feature

Rear Cargo Management System

- Located under the rear loadfloor
- Includes handle for easy access
- Has stationary plastic bins that help utilize the space around the spare tire
- Helps to organize smaller items such as a first-aid kit, jumper cables, flashlight, etc.
- Keeps small items from rolling around the cargo area



Auxiliary Power Points

- Edge features four auxiliary power points located:
 - At the bottom of the instrument panel center stack
 - Inside the floor center console
 - On the rear face of the floor center console
 - On the left rear trim panel in the cargo area

2010 Edge

Comfort/Convenience

COMFORT/CONVENIENCE

This page is about:

- Remote Keyless Entry System with Integrated Keyhead Transmitter
- Eight Drink Holders
- Privacy Cover
- Option Packages

Interior cont'd

Remote Keyless Entry System with Integrated Keyhead Transmitter

- Replaces the standard key and separate Remote Keyless Entry fob combination with a single integrated keyhead transmitter
- System operates all door and liftgate locks and power liftgate (if equipped) and includes a panic button

Eight Drink Holders

- 20-ounce holder in each front door map pocket
- Juice box holders in the rear door pockets
- Two super-size cup holders in the center console
- Two super-size cup holders in the rear armrest

Privacy Cover

- A heavy-duty vinyl cover attaches to the back of the rear seat and affixes to dealer-installed hooks, helping to conceal cargo content
- Available in colors to match the vehicle interior

ENGINEERING INSIGHT

Integrated Keyhead Transmitter

The integrated keyhead transmitter is designed so customers won't accidentally activate the panic alarm while inserting or removing the key from the ignition or their pocket. To avoid any confusion or unnecessary repair visits, review these features with your customers:

- Lock/unlock functions work the same as traditional Ford key fobs
- To activate the panic alarm, press and hold the button for 1.5 seconds or longer
- To use the "car finder" feature, push the Lock button twice in 3 seconds
- Horn will chirp and the vehicle turn signals will flash once

For more details on the recommended handling of the integrated keyhead transmitter, refer to the vehicle Owner's Guide.

Option Packages

Convenience Package

- Automatic on/off headlamps with wiper activation
- Electrochromic auto-dimming rearview mirror
- SecuriCode™ Keyless Entry Keypad
- Steering-wheel audio controls
- Reverse Sensing System
- Included in SE Rapid Spec 101A

SPORT Premium Package

- Heated front seats
- 6-way power front passenger seat with fold-flat seatback
- Memory driver's seat
- Heated, memory exterior mirrors with security approach lamps
- Dual-zone Electronic Automatic Temperature Control
- Universal garage door opener
- Power liftgate
- Included in SPORT Rapid Spec 401A

Cargo Package

- Power liftgate
- Rear cargo management system
- Optional with SEL Rapid Spec 201A and 202A
- Optional with Limited Rapid Spec 300A and 301A, included in 302A

Leather Comfort Package

- Leather-trimmed seats
- Heated front seats
- 6-way power passenger seat with fold-flat seatback
- Dual-zone Electronic Automatic Temperature Control
- Included in SEL Rapid Spec 202A

Navigation Package

- Voice-activated Navigation System with SIRIUS Travel Link™
- Premium audio system with 9 speakers
- Available with SEL Rapid Spec 202A and SPORT 401A

Limited Interior Appearance Package

- Unique Sienna leather-trimmed seats with accent stitching
- Accent stitching on leather-wrapped steering wheel and shifter handle
- Dark brushed aluminum center stack appliqué
- Premium floor mats with "Edge" logo
- Available with Limited Rapid Spec 300A, 301A and 302A

2010 Edge

Comfort/Convenience

This page is about:

- Audio Systems
- SIRIUS® Satellite Radio
- SYNC®
- Voice-activated Navigation System with SIRIUS Travel Link™
- SIRIUS Travel Link

Audio/Navigation/Entertainment

Audio Systems

- MP3 capable
- SIRIUS Satellite Radio capable
- Single-disc CD with 4 speakers
- 6-disc in-dash CD/MP3 capability
- Premium Sound System with 6-disc in-dash CD and 9 speakers
- Auxiliary audio input jack

NOTE: See page 24 for more information.

SIRIUS® Satellite Radio

- Over 130 channels
- Commercial-free music
- Digital sound quality
- Seamless coverage anywhere in the 48 contiguous states and Washington D.C.
- 6-month complimentary subscription subject to geographic location and availability

NOTE: See page 26 for more information.

SYNC®(1)

Ford and Microsoft® have teamed up to develop SYNC. This Ford-exclusive technology will change the way customers use their digital media and Bluetooth®(2) wireless technology enabled mobile phones. SYNC allows drivers to stay connected to the information, entertainment and people they care about while on the road. SYNC features:

- Traffic, Directions and Information is new for 2010
 - Includes a complimentary 3-year prepaid subscription
- 911 Assist™
- Vehicle Health Report (VHR)
- Voice-activated hands-free calling
- Uninterrupted connections that allow going directly from mobile phone to the vehicle's hands-free phone during the call
- Audible text messages
- Advanced calling features like caller ID, call waiting, conference calling and more
- Voice-activated control of an MP3-style media player
- Instant voice recognition
- Ringtone support
- Automatic phone book transfer for mobile phones with this feature
- Multilingual intelligence (English, French, Spanish)
- For more information, go to syncmyride.com

NOTE: SYNC® Traffic, Directions and Information services are replaced by the vehicle's Navigation System and SIRIUS Travel Link™ functionality in vehicles equipped with the combination of SYNC and the Voice-activated Navigation System. See page 19 for more information.

Voice-activated Navigation System with SIRIUS Travel Link™

- 6.5" LCD touch-screen display
- Real-time traffic and weather reports provided by SIRIUS Travel Link
- 10 GB Music Jukebox for storage and access to around 2,400 songs
- Integrated climate control functions
 - Temperature
 - Mode
 - Fan speed
- Voice-activated climate control functions
 - Temperature
 - Fan speed
- Fast route calculations, zooming, scrolling and route previews
- Audible step-by-step route guidance feature that announces upcoming maneuver with specific street names
- Capable of playing DVD-based movies while vehicle is in Park

NOTE: Includes a single-disc version of the Premium Sound System. See page 25 for more information.

SIRIUS Travel Link®(3)

- 6-month complimentary subscription subject to geographic location and availability
- Real-time traffic updates every 2.5 minutes and includes automatic rerouting capability
- Weather updates provide current weather and five-day forecast
- Fuel pricing for over 120,000 gas stations
- Sports updates and movie listings

NOTE: See page 25 for more information.

(1) Driving while distracted can result in loss of vehicle control. Only use mobile phones and other devices, even with voice commands, when it's safe to do so.

(2) The Bluetooth word mark is a trademark of the Bluetooth, SIG, Inc.

(3) Real-time traffic monitoring available in select markets. Some features are unavailable while driving. Service available in the 48 contiguous states and Washington, D.C. SIRIUS Travel Link is a trademark of SIRIUS XM Radio, Inc.

2010 Edge

Comfort/Convenience

COMFORT/CONVENIENCE

This page is about:

- Traffic, Directions and Information
- 911 Assist™
- Vehicle Health Report (VHR)

SYNC® Technology

Traffic, Directions and Information⁽¹⁾

- Ford-exclusive technology
- Includes a complimentary 3-year prepaid subscription
- Provides simple voice command access to traffic reports, turn-by-turn driving directions, business listings, sports scores, weather forecasts and news
- Updatable by logging on to syncmyride.com
- **Traffic** provides traffic reports between two points, such as home and work
 - Also provides text message traffic alerts to the owner's mobile phone
 - Customers can use their online SYNC owner account to set up personalized address points
- **Directions** provide easy-to-understand in-vehicle driving directions to businesses, personalized locations or specific street addresses
 - The Directions service uses the same personalized address points that are used for Traffic
- **Information** provides access to:
 - Business Search by name or category with results provided in vehicle, including turn-by-turn directions and telephone number
 - News reports in a variety of categories
 - Sports scores
 - Weather information for a number of U.S. cities
 - Favorites allows customers quick access to their favorite news, sports and weather information

NOTE: SYNC® Traffic, Directions and Information services are replaced by the vehicle's Navigation System and SIRIUS Travel Link™ functionality in vehicles equipped with the combination of SYNC and the Voice-activated Navigation System.

911 Assist™

- Assists occupants in placing a 911 call in certain vehicle crashes by using a properly paired and connected mobile phone inside the vehicle⁽²⁾
- Occupants can cancel the call by pressing and holding the phone button on the steering wheel, or by confirming the cancellation message on the Navigation System screen
- Connects to a 911 operator informing them of the accident
- Opens the SYNC microphone to allow vehicle occupants to communicate hands-free with the 911 operator

Vehicle Health Report (VHR)⁽¹⁾

- Produces an easy-to-understand report accessible on syncmyride.com
- Customers are able to monitor the operating condition of their vehicle and work closely with the dealership to keep it in peak running condition
- VHR combines data from multiple sources to communicate diagnostic, recall and maintenance information
- Provides the capability to seamlessly schedule dealership service via the dealer Web site, via Genuine eService or by e-mail
- Vehicle Health Overview includes:
 - Brakes and suspension
 - Checks, fluids and filters
 - Engine, transmissions and emissions systems
 - Restraints and driver assistance
- Will notify the customer of:
 - Recommended scheduled maintenance based on current odometer reading
 - Recalls and Field Service Actions requested by Ford Motor Company to repair certain safety- or emissions-related concerns



(1) Driving while distracted can result in loss of vehicle control. Only use mobile phones and other devices, even with voice commands, when it's safe to do so.

(2) The vehicle electrical system (including the battery), the wireless service provider's signal and a connected mobile phone all must be available and operating for 911 Assist to function properly. These systems may become damaged in a crash. The paired mobile phone must be connected to SYNC and the 911 Assist feature enabled for 911 to be dialed.

This page is about:

- Accident Avoidance
- Occupant Protection
- Child Safety
- Personal Security
- Crash Test Ratings

Overview

Key Messages

EDGE

- Strong unibody structure helps protect occupants in a collision
- AdvanceTrac® with RSC® (Roll Stability Control™) helps the driver maintain vehicle control
- Available All-Wheel Drive helps the driver maintain control in poor driving conditions
- Safety Canopy® System with rollover sensor

Key Features

Accident Avoidance

AdvanceTrac® with RSC® (Roll Stability Control™) helps the driver maintain vehicle control in adverse driving situations or when making evasive maneuvers on slippery pavement.

Traction Control helps provide control by limiting wheel spin to maximize available traction.

Available All-Wheel Drive helps maintain traction in a variety of driving conditions.

Four-wheel Anti-lock Braking System (ABS) prevents wheel lock during excessive braking to help maintain steering control.

Occupant Protection

Personal Safety System™ deploys airbags based on crash severity, safety belt usage, driver's-seat position and front passenger weight classification.

Safety Canopy® System with rollover sensor deploys side curtain airbags for all outboard seating occupants in side-impact and rollover situations.

Front-seat side airbags help protect front-seat occupants in certain side collisions.

Side Door Intrusion Beams help prevent intrusion into the passenger compartment in a side-impact collision.

Child Safety

LATCH System (Lower Anchors and Tethers for Children) helps provide secure and correct installation of child safety seats.

Rear-door child safety locks prevent rear-seat occupants from opening the door from the inside.

Personal Security

SecuriLock® passive anti-theft system requires a key specially coded with billions of possible codes to start the vehicle.

Perimeter anti-theft system helps prevent unauthorized entry when the vehicle is locked.

SOS Post Crash Alert System activates the hazard flashers and sounds the horn after a crash in which the airbags deploy.⁽¹⁾ Sounding the horn and flashing the hazards makes the vehicle easier to locate if the accident happens off the roadway. System operates until deactivated or battery power is depleted.

(1) SOS hardware may become damaged or the battery may lose power in a crash, which could prevent operation. Not all crashes will activate an airbag.

Crash Test Ratings

NHTSA Tests

Edge received high ratings in all four impact categories in tests conducted by the National Highway Traffic Safety Administration (NHTSA).

- For a complete list of NHTSA results, visit safercar.gov

	Frontal-impact Rating		Side-impact Rating	
	Driver	Passenger	Front Seat	Rear Seat
Edge	★★★★★	★★★★	★★★★★	★★★★★

What Do the Stars Mean?

Frontal-impact Testing

- ★★★★★ 5 stars = 10 percent or less chance of serious injury
- ★★★★ 4 stars = 11 to 20 percent or less chance of serious injury

Side-impact Testing

- ★★★★★ 5 stars = 5 percent or less chance of serious injury

IIHS Top Safety Pick

2009 Edge received the highest possible rating in each of the tests performed by the Insurance Institute for Highway Safety (IIHS). 2010 Edge is anticipated to achieve these same ratings when tested.

- For a complete list of IIHS results, visit IIHS.org

IIHS Top Safety Pick	
IIHS Test	Test Evaluation Result
Frontal Offset	Good
Side Impact	Good
Rear Impact	Good
Stability Control	Available ⁽¹⁾

(1) Edge features standard AdvanceTrac with RSC.

This page is about:

AdvanceTrac® with RSC®	—
Roll Stability Control	—
Brake Assist	—
All-Wheel Drive (AWD)	—
AWD Benefits	—
Tire Pressure Monitoring System (TPMS)	—

Accident Avoidance



AdvanceTrac® with RSC®

- An electronic stability control system that helps the driver maintain vehicle stability in adverse driving situations or when making evasive maneuvers on slippery pavement
- Monitors vehicle's cornering behavior with steering angle, lateral acceleration and yaw rate sensors, and automatically makes braking and throttle adjustments to match vehicle's direction to the driver's intention using Anti-lock Braking System (ABS) and Traction Control components
- AdvanceTrac automatically activates whenever the vehicle is started, but may be turned off for certain situations such as when "rocking" a vehicle stuck in mud or snow

NOTE: See the Safety section in the Source Book Appendices or on **eSourceBook** for more information.

Roll Stability Control

- RSC is an additional vehicle control software module
- Builds on the ABS, Traction Control and yaw control systems of AdvanceTrac to help keep the vehicle tires on the ground by monitoring and helping control vehicle roll rate

NOTE: Please remember that even sophisticated, advanced technologies cannot defy the laws of physics. Encourage safer driving habits to your customers.

Brake Assist

- Recognizes when the brake pedal is applied suddenly but without enough force to provide full deceleration
- With Brake Assist, the system engages the appropriate pressure to maximize vehicle deceleration and help reduce stopping distances
- Without the Brake Assist feature, the result could be a longer stopping distance than desired
- Once the driver releases the brake pedal, the vehicle returns to normal braking mode

All-Wheel Drive (AWD)

- Continuously monitors wheel speed, throttle position and steering angle to determine the vehicle's conditions and driver's intent
- System then determines the optimal amount of front and rear torque for the given conditions to not only reduce wheel slip but to prevent the slip from occurring in the first place, which helps keep the vehicle surefooted in a variety of conditions — slippery surfaces and anything that compromises traction

AWD Benefits

- No need to activate AWD — it's transparent to the driver and always there when it's needed, for wet or dry pavement, creating driving confidence and peace of mind
- Since the system can transfer torque away from the front wheels, it helps reduce the type of understeer often associated with front-wheel-drive vehicles, providing improved vehicle control
- When AWD is combined with Traction Control or the AdvanceTrac® system, a high degree of torque can be sent to the wheel with the best traction, even if the other three wheels have no traction at all

NOTE: See the AWD/4WD Operations section in the Source Book Appendices or on **eSourceBook** for more information.



For an online animated demonstration of AWD, go to esourcebook.dealerconnection.com.

Tire Pressure Monitoring System (TPMS)

- Sensor-based system alerts the driver to significant underinflation in any of the tires, excluding the spare
- Pressure sensors in the valve stems detect actual tire pressure and activate a warning light in the vehicle's Message Center when a tire is significantly underinflated

NOTE: See the Safety section in the Source Book Appendices or on **eSourceBook** for more information.

This page is about:

- Personal Safety System™
- Safety Canopy® System with Rollover Sensor
- Front-seat Side Airbags
- Solid Unibody Construction
- LATCH System (Lower Anchors and Tethers for Children)
- SecuriLock® Passive Anti-theft System

2010 Edge

Safety/Security

Occupant Protection

Personal Safety System™

- Dual-stage driver and front passenger airbags
- Electronic front crash severity sensor
- Driver's-seat position sensor
- Front outboard safety belt usage sensor
- Restraint Control Module
- Front outboard safety belt energy management retractors
- Front outboard safety belt pretensioners
- Front Passenger Sensing System (FPSS)

NOTE: See the Safety section in the Source Book Appendices or on **eSourceBook** for more information.

Safety Canopy® System with Rollover Sensor

- Side curtain airbags provide head protection for all outboard seating positions
- System includes side curtain airbags and rollover sensor
- Located in the roof side rail behind the headliner, the side curtain airbags deploy downward and outward toward the side window opening to protect the heads of outboard passengers
- Side air curtains are triggered independently of the driver and front passenger airbags by side-impact sensors or by the rollover sensor
- Roll-fold technology helps the airbag slide between the glass and occupant as it inflates
- Side curtain airbags will not interfere with properly installed child safety seats or booster seats
- Canopy is designed to stay inflated longer for added protection in a rollover or multiple side impacts

Front-seat Side Airbags

- Side-impact airbags help protect front-seat occupants in certain side collisions
- Airbags deploy from the front seats to protect occupants' chests
- Placed in the front seatbacks, so they are always in the optimum deployment position no matter where the seat is positioned
- Designed to help protect the chest in certain side collisions

Solid Unibody Construction

- Provides an energy-absorbing structure to help protect occupants
- Bumper-to-bumper flow-through side rails, structural design and A-pillars are designed to move crash energy away from occupants
- Extensive use of high-strength steel creates a strong, solid body structure and reinforced greenhouse to improve safety performance

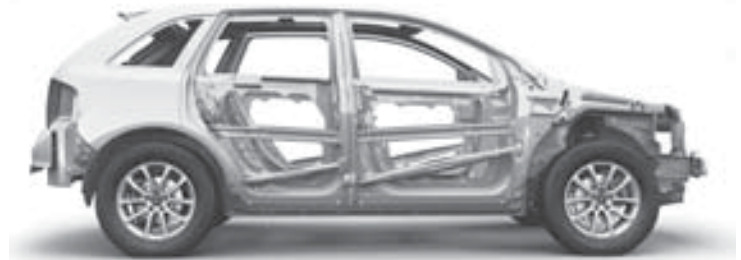

Child Safety

LATCH System (Lower Anchors and Tethers for Children)

- Consists of a top tether anchor point and two rigid bars located where the seat cushion meets the seatback
- All rear seats offer LATCH provisions
- LATCH-compatible child safety seat attaches to the lower anchor points by means of flexible tethers or rigid latch bars
- LATCH can eliminate the need to use the safety belts when installing a child safety seat, providing a secure attachment and helping to reduce the likelihood of incorrect installation
- Uniform installation method helps eliminate the confusion associated with a variety of safety belt systems

NOTE: See the vehicle Owner's Guide for more information.

Personal Security

SecuriLock® Passive Anti-theft System

- Uses a specially coded ignition key with billions of possible codes to start the vehicle
- Designed to help prevent the engine from being started unless a coded key programmed to the vehicle is used

24-Hour Roadside Assistance

- Toll-free number (1-800-241-FORD) operational 24 hours, 7 days a week
- Customers can request services to change a flat tire, jump-start a battery, deliver fuel or tow the vehicle
- Available for 5 years or 60,000 miles, whichever comes first

2010 Edge

Quality/Reliability/Durability

QUALITY/RELIABILITY/DURABILITY

This page is about:

- Smooth Operation and Low NVH Levels
- Durability Testing
- Cost of Ownership
- Environmental Features
- Powertrain Limited Warranty
- 24-Hour Roadside Assistance

Overview

Key Messages

EDGE



- Low levels of NVH (Noise, Vibration and Harshness)
- Exceptionally clean-operating and efficient engine
- Stringent testing during the development of the Edge helped ensure its quality, reliability and durability

Key Features

Smooth Operation and Low NVH Levels

The elimination of NVH (Noise, Vibration and Harshness) was a top priority for Edge engineers. Every area of the vehicle was studied to provide smooth, quiet operation.

- Powertrain engineers focused on the way the engine and transmission work together, nearly eliminating the bending that occurs under acceleration. This work resulted in smooth launches and shifts
- Side mirrors were specifically designed to reduce wind noise
- The pitch and height of the spiral of the radio antenna were modified by tenths of a millimeter, reducing wind noise by as much as two decibels
- A liner fused inside the rear wheelhouse and gussets helps block road noise
- Lightweight dash insulation system absorbs powertrain noise
- Specially designed sound-deadening material is sonic-welded behind the headliner and nearly every interior trim panel to further reduce cabin noise
- The available Vista Roof™ has the thickest available roof glass (5mm) ever offered by Ford Motor Company, for enhanced interior quietness

Durability Testing

Subjected to stringent testing for quality, reliability and durability:

- Crossover durability testing is more rugged than testing for a passenger car
- Vista Roof is the most analyzed/tested moonroof in the history of Ford Motor Company
- Vista Roof was wind-tested with wind coming at multiple angles and high speeds
- Vista Roof was also tested for water leaks, with the vehicle positioned at different road angles
- Vista Roof is designed to prevent leakage, even in the vent position during a torrential downpour
 - It can manage 1.2 gallons of water per minute at a 15 percent incline with all the water channeled to one corner

Cost of Ownership

Includes features that help reduce the cost of ownership:

- 7,500-mile oil change interval
- Filled-for-life automatic transmission fluid
- 3.5L Duratec® V6 engine requires less-expensive 87-octane regular fuel to operate

Environmental Features

Engineers paid special attention to the combustion and exhaust systems. The powertrain team focused on four areas to deliver an ultra-clean, reliable engine.

- The high 10.3:1 compression ratio improves both fuel economy and power while still meeting Federal or California emissions standards
- Low heat-loss exhaust manifolds and close-coupled catalysts for fast light-off during cold starts help minimize cold start emissions before the catalysts reach operating temperature
- Optimized fuel injector targeting helps minimize cold start emissions
- Centrally located spark plugs increase the engine's thermal efficiency

Edge is certified to the tailpipe emissions standard of Ultra Low Emissions Vehicle (ULEV II) in California Emissions States or U.S. Environmental Protection Agency (EPA) Tier 2 Bin 5.

Powertrain Limited Warranty

- Powertrain Limited Warranty for Ford vehicles is 5 years or 60,000 miles, whichever comes first
- That's an additional 2 years/24,000 miles of coverage for components such as the engine, transmission and front- or rear-wheel drive parts (refer to the vehicle Owner's Guide for a more comprehensive listing of all the parts covered) beyond the vehicle's 3-year/36,000-mile Bumper-to-Bumper limited warranty

24-Hour Roadside Assistance

- Toll-free number (1-800-241-FORD) operational 24 hours a day, every day
- Customers can request services to change a flat tire, jump-start a battery, unlock the vehicle, deliver fuel or tow the vehicle
- Available for 5 years or 60,000 miles, whichever comes first

This page is about:

- Single-disc CD/MP3 Capability
- 6-disc In-dash CD/MP3 Capability
- Premium Sound System 6-disc In-dash CD/MP3 Capability

All Edge Audio Systems Include

- MP3 capability
- Station Memory Presets — 12 FM, 6 AM
- Autoset (AST) automatically locates 6 strongest AM or FM station signals
- Auxiliary audio input jack
- Digital clock

Single-disc CD/MP3 Capability

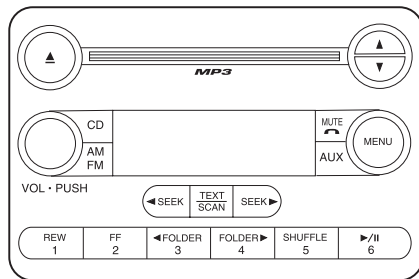

- 80 watts of power
- 4 speakers
- **Speed Compensated Volume (SCV)** compensates for changing ambient noise levels by adjusting the volume of the radio according to the vehicle's speed signal. Allows 7 volume adjustment levels. Adjustable through the menu
- **Compression** allows the audio dynamic range to be compressed so quieter music is boosted and louder music is lowered to compensate for ambient noise level when enabled during CD mode
- **Repeat** will play the selected track continuously until Repeat is deactivated when enabled during CD mode
- **Shuffle** plays CD/MP3 tracks in random order
- **Folder** button allows access to the MP3 folder
- **Folder/track mode** allows the audio system to play and seek through disc tracks with or without folder option (available with MP3 discs only)

6-disc In-dash CD/MP3 Capability

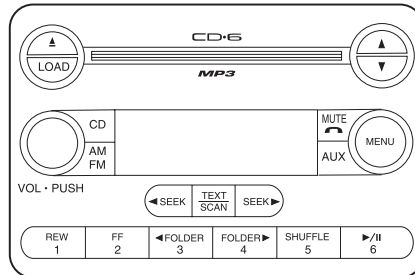

Includes or replaces features of single-disc CD/MP3 capability plus:

- 6-disc CD changer
- **RBDS (Radio Broadcast Data System) function** when selected, allows the following:
 - Only for FM radio stations supporting RBDS capability
 - Radio station call letters appear on radio display
 - Type of music format appears on radio display
 - Search for type of music format
 - Traffic information broadcasts

Premium Sound System 6-disc In-dash CD/MP3 Capability

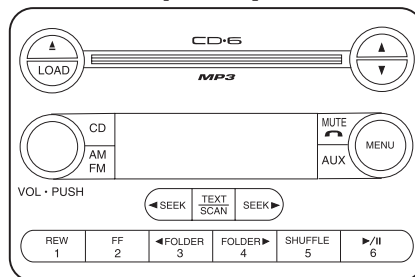

Includes or replaces features of 6-disc in-dash CD/MP3 capability plus:

- 190 watts of power
- 8 speakers plus an 8" subwoofer
- **Occupancy setting** allows one of three vehicle acoustic settings to be chosen: all seats, driver's seat or rear seats

For More Audio Information

- Audio availability: See the latest Dealer Ordering Guide
- Operating information: See the vehicle Owner's Guide

Voice-activated Navigation System with SIRIUS Travel Link™



- Includes a single-disc version of the Premium Sound System with:
 - 18 station memory presets (12 FM and 6 AM)
 - 18 satellite radio station memory presets
- **Voice activation** recognizes certain voice commands to operate the system hands-free
- **6.5" LCD touch screen** operates navigation and audio functions
- Integrated **climate control** functions
- **Traffic and weather information, fuel pricing, sports updates and movie listings** provided by SIRIUS Travel Link
 - Learn more about the capabilities of SIRIUS Travel Link in the "A Closer Look" box at right
- **Bird's-eye map** provides a "3D" view of route, landmarks and Points of Interest (POI)
- **Hard-drive-based system** includes 10 GB of storage for music and photos
- **Music Jukebox capability** allows for storage and access to around 2,400 songs
 - Browse the music library via the touch screen or by voice recognition
 - Music can be sorted by playlists
- **Upload photos** to the home screen
- **Park and Play** mode allows DVDs to be played while vehicle is in Park
- **Destination selection search** methods include:
 - Street address
 - Increased Points of Interest (POIs), including retail
 - Freeway entrance/exit search
 - Previous destination
- **Route Guidance** with turn-by-turn voice directions
 - Street name announcements
 - Freeway exit, turn and ramp transition lane guidance
 - Speed limit display on freeways
- Supports North American English, Canadian French and Mexican Spanish
- **Help menu** for basic operation, driving restrictions and navigation DVD
- **Automatic rerouting** recalculates a new route if a turn is missed
- **Emergency button** provides nearest emergency facility to choose as a destination (hospital or police)
- **Valet Lockout Mode** disables operation of the navigation and audio systems
- **Address book** saves the most frequently used destinations for quick and easy routing

A CLOSER LOOK: SIRIUS Travel Link⁽¹⁾

- **6-month complimentary subscription** subject to geographic location and availability (included with Navigation System)
- **Real-time traffic info**
 - Provides incident, speed and flow information for 80 major cities in the continental U.S.
 - Updates every 2.5 minutes
 - View graphical overlay of incidents
 - Route recalculation based on traffic data
- **Real-time weather info**
 - Provides current weather and 5-day forecast reports that are updated every 5 minutes
 - Current conditions update every 30 minutes
 - Region of interest can be defined by customer
- **Fuel pricing** for over 120,000 gas stations
 - Search for pricing en route or based on current location
 - Displays pricing for regular, mid-grade and premium when available
- **Sports updates and movie listings**
 - Score summaries and schedules for major sports
 - Updates every 5 minutes
 - User can personalize for favorite teams
 - Movie listings for over 4,500 theaters, including times, movie summary and directions to the theater
- More information is available online at www.sirius.com or toll-free at (888) 539-SIRIUS (7474)

(1) Real-time traffic monitoring available in select markets. Some features are unavailable while driving. Service available in the 48 contiguous states and Washington, D.C. SIRIUS Travel Link is a trademark of SIRIUS XM Radio, Inc.

For More Audio Information

- Audio availability: See the latest Dealer Ordering Guide
- Operating information: See the vehicle Owner's Guide

This page is about:

- SIRIUS® Satellite Radio
- Auxiliary Audio Input Jack

SIRIUS® Satellite Radio

- **Includes 6 months of SIRIUS service** subject to geographic location and availability
- Unit is preactivated from the factory
- SIRIUS Satellite Radio can be accessed using existing radio head controls:
 - **Aux button** — press and release to enter satellite radio mode
 - **Seek/Scan** — use these buttons to change channels
- Key benefits of SIRIUS Satellite Radio include:
 - Over 130 channels of the best music, talk, news, sports and information (65 music channels)
 - 100 percent commercial-free music
 - Seamless coverage anywhere in the 48 contiguous states and Washington, D.C.
- More information is available online at www.sirius.com or toll-free at (888) 539-SIRIUS (7474)

Auxiliary Audio Input Jack

- Allows the use of portable MP3 players
- Vehicle audio system will not control the functions of the MP3 player









2010 Edge Wheels

WHEELS

This page is about:

- 17" Painted Aluminum —
- 18" Painted Aluminum —
- 18" Chrome-Clad Aluminum —
- 20" Chrome-Clad Aluminum —
- 22" Bright Polished Aluminum —

Wheel		SE	SEL	Limited	SPORT
17" Painted Aluminum Wheel (64F)		Standard	—	—	—
18" Painted Aluminum Wheel (64R)		—	Standard	—	—
18" Chrome-Clad Aluminum Wheel (64G)		—	Optional	Standard	—
20" Chrome-Clad Aluminum Wheel (647)		—	—	Optional	—
20" Chrome-Clad Aluminum wheel with "SPORT" center cap		—	—	—	Standard
22" Bright Polished Aluminum Wheel with "SPORT" center cap (64K)		—	—	—	Optional

— = Not available

NOTE: See the latest Dealer Ordering Guide for wheel availability.

COLOR AND TRIM

This page is about:

- Color and Trim Availability
- Interior Trim

2010 Edge

Color and Trim

Color and Trim Availability

Paint Name	Order Code	SE		SEL/Limited			Limited Interior Appearance Package	SPORT
		Cloth		Leather	Cloth ⁽¹⁾ /Leather	Cloth ⁽¹⁾ /Leather	Leather	Leather
		Med. Lt. Stone	Charcoal Black	Camel	Med. Lt. Stone	Charcoal Black	Charcoal Black	Charcoal Black
		1L	1W	3H	2L/3L	2W/3W	8W	5W
New Ingot Silver Metallic	UX	■	■		■	■	■	■
New Red Candy Metallic with Tinted Clearcoat ⁽²⁾	U6	■	■	■	■	■		■
New Tuxedo Black Metallic	UH	■	■	■	■	■	■	■
Cinnamon Metallic	HT			■		■	■	
Dark Ink Blue Metallic	DI	■	■		■	■		
Sport Blue Metallic	U1							■
Sterling Grey Metallic	UJ				■	■	■	
White Platinum Metallic Tri-coat ⁽²⁾	UG			■	■	■	■	
White Suede	WS	■	■		■	■		

(1) Cloth not available on Limited.
 (2) Extra-cost option.

Interior Trim

Model	Style/Material	Interior Description
SE	Cloth	Cloth front bucket seats with 60/40 fold-flat rear bench seat (5-passenger)
SEL	Cloth	Unique cloth front bucket seats with 60/40 fold-flat rear bench seat (5-passenger)
SEL ⁽¹⁾ /Limited	Leather	Leather-trimmed front bucket seats with fold-flat front passenger seatback and 60/40 fold-flat rear bench seat (5-passenger)
Limited Interior Appearance Package	Leather	Charcoal Black interior with Sienna leather-trimmed front bucket seats, fold-flat front passenger seatback and 60/40 fold-flat rear bench seat (5-passenger)
SPORT	Leather	Leather-trimmed front bucket seats with Alcantara® Grey inserts and accent stitching, fold-flat front passenger seatback and 60/40 fold-flat rear bench seat (5-passenger)

(1) Requires Leather Comfort Package.

NOTE: See the 2010 Color & Upholstery Selections Guide or the Specifications section on eSourceBook for illustrations of the available seating choices.

2010 Edge

Instrument Cluster

INSTRUMENT CLUSTER

This page is about:

Instrument Cluster

Instrument Cluster

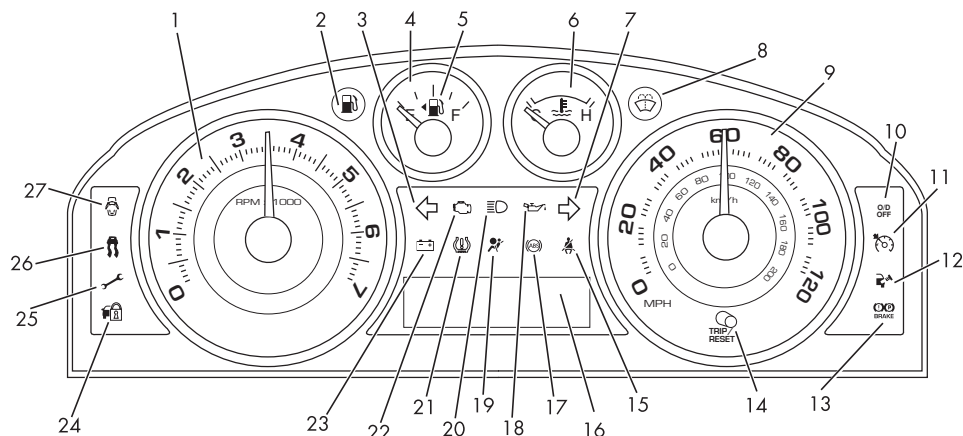

- | | | |
|---|---|---|
| 1. Tachometer | 12. Loose fuel cap warning light | 20. High-beam indicator |
| 2. Low fuel warning light | 13. Brake system warning light/parking
brake indicator | 21. Low tire pressure warning light |
| 3. Left turn signal indicator | 14. Trip odometer reset button | 22. Check engine warning light |
| 4. Fuel gauge | 15. Fasten safety belt warning light | 23. Charging system warning light |
| 5. Fuel filler door location indicator | 16. Odometer/trip odometer | 24. Anti-theft system active indicator |
| 6. Engine coolant temperature gauge | 17. Anti-lock Braking System (ABS)
readiness indicator/warning light | 25. Throttle control/transmission fault
warning light |
| 7. Right turn signal indicator | 18. Low engine oil pressure
warning light | 26. AdvanceTrac®/Traction Control
active indicator light |
| 8. Low windshield washer fluid
warning light | 19. Airbag readiness indicator/
warning light | 27. Door ajar warning light |
| 9. Speedometer | | |
| 10. Overdrive off indicator | | |
| 11. Speed control active indicator | | |

2010 Edge

Key Product Specifications⁽¹⁾

Model	4-Door
Wheelbase	111.2
Length	185.7
Height (without options)	67.0
Height (with options)	69.0
Width	87.5
Track (Front/Rear)	65.4/64.7
Curb Weight (approx. lbs.)	
FWD	4078
AWD	4288

Front/Rear Seating	
Seating Capacity	5
Head Room (Front/Rear)	40.0/39.3
Shoulder Room (Front/Rear)	58.9/58.8
Hip Room (Front/Rear)	54.8/56.3
Leg Room (Front/Rear)	40.7/39.6

Passenger/Luggage/Fuel Capacity	
Interior Volume (cu. ft.)	108.4
Cargo Volume (cu. ft.)	
– behind 1st row	69.0
– behind 2nd row	32.2
Fuel Tank Capacity (gal.)	19.2 (FWD)/20.8 (AWD)

Engine	
Engine Layout	Front engine, front drive
Engine Type	3.5L DOHC V6
Displacement (liters/cu. in.)	3.5/213
Horsepower @ rpm	265 @ 6250
Torque (lb.-ft.) @ rpm	250 @ 4500
Compression Ratio	10.3:1
Bore & Stroke	3.6 x 3.4
Fuel System	Sequential Multi-port Fuel Injection
Fuel Requirement	87 octane (minimum)
Exhaust System	Dual with catalytic converters

EPA-estimated Fuel Economy	
FWD (city/hwy. mpg)	18/25
AWD (city/hwy. mpg)	17/23

Transmission	
Type	6-speed Automatic
Final Drive Ratio	3.16 (FWD/AWD)

Gear Ratios						
Gears	1st	2nd	3rd	4th	5th	6th
6-Speed Automatic	4.48:1	2.87:1	1.84:1	1.41:1	1.00:1	0.74:1
	Rev.					
	2.88:1					

Front Suspension	
Type	Independent MacPherson struts with L-shaped lower control arms and isolated subframe
Springs	Helical coil
Shock Absorbers	Gas-pressurized hydraulic
Stabilizer Bar Diameter	33mm (FWD), 33mm (AWD)

Rear Suspension	
Type	Independent multi-link with trailing blade control arms and isolated subframe
Springs	Helical coil
Shock Absorbers	Gas-pressurized hydraulic
Stabilizer Bar Diameter	23mm (FWD), 23mm (AWD)

Steering	
Type	Power rack-and-pinion
Overall Ratio	17.7:1 on center
Turning Diameter Curb-to-Curb (ft.)	38.6

Brakes	
Standard	Power four-wheel disc with Anti-lock Braking System (ABS)

Aerodynamics	
Coefficient of Drag (Cd)	0.367 (17" wheels) 0.376 (18" wheels)

Trailer Towing ⁽²⁾	
Towing Class	Light Duty (std.) Medium Duty (opt.)
Gross Trailer Weight (lbs.)	2000 lbs. max. or less (std.) 3500 lbs. max. or less (opt.; requires Trailer Tow Package)
Maximum Tongue Weight (lbs.)	200 lbs. (std.) 350 lbs. (opt.)
Hitch Design	Load-carrying

Flat/Neutral Towing	
	Also known as four-wheel-down towing, it refers to towing a vehicle with all four of its wheels on the ground — for example, when towing a vehicle behind a motorhome. All 2010 Edge models can be flat towed. See the vehicle Owner's Guide for complete details.

(1) Dimensions are in inches unless otherwise specified.

(2) See the RV & Trailer Towing Guide, available on eSourceBook as a printable PDF, or the vehicle Owner's Guide for additional towing information.