

What's Important / 2 - 3

Model Lineup / 4 - 5

Purchase Motivators	Reference
Comfort/Convenience / 6 - 11	Audio/Navigation/Entertainment / 25 - 27
Design/Styling / 12 - 14	Wheels / 28
Performance/Handling / 15 - 18	Interior Trim/Instrument Cluster / 29
Safety/Security / 19 - 23	Key Product Specifications / 30
Quality/Reliability/Durability / 24	Accessories / 31 - 32

AdvanceTrac® with RSC® (Roll Stability Control™) / 19, 20  
 Airbags, Front-seat Side / 19, 23  
 All-wheel Drive (AWD) / 15, 18, 19, 21  
 Anti-theft Systems  
     Perimeter / 19, 23  
     SecuriLock® Passive / 19, 23  
 Audio Systems  
     AM/FM Stereo/Single-disc CD Capability / 11, 25  
     AM/FM Stereo/6-disc In-dash CD/MP3 Capability / 11, 25  
     Sony® Premium AM/FM Stereo/6-disc In-dash CD/MP3 Capability / 11, 25  
     SIRIUS® Satellite Radio / 11, 27  
     Auxiliary Audio Input Jack / 27  
 Belt-Minder® System / 19  
 Brakes  
     Anti-lock Braking System (ABS) / 19, 20  
     Disc, Four-wheel / 15, 18  
     Brake Assist / 19, 20  
     Electronic Brake Force Distribution (EBD) / 18, 19  
 Camera, Rear View / 26  
 Child Safety Locks, Rear Door / 19  
 Climate Control Systems  
     Dual-zone Electronic Automatic Temperature Control / 9  
     Rear Auxiliary Climate Control / 9  
 Clock, Analog / 12  
 Colors, Exterior / 13  
 Colors, Interior / 14  
 Console  
     Front / 8  
     Second-row, Refrigerated / 6, 8  
 DVD Entertainment System / 6, 11, 27  
 Easy Fuel™ Capless Fuel Filler System / 6, 7  
 Engine  
     Duratec 35 - 3.5L DOHC V6 / 15, 16  
     intake-Variable Cam Timing (i-VCT) / 15, 16  
 Footrests, Second-row / 10  
 Ford SYNC® / 6, 11  
 Fuel Economy / 16  
 Garage Door Opener, Universal / 9  
 Greenhouse, Unique / 12  
 Grille, Tri-bar / 12  
 Grooves, Horizontal / 12  
 Inverter, 110-volt (Power Point Outlet) / 8  
 Keyless Entry Keypad, SecuriCode™ Next Generation / 7, 12  
 Lamps, Exterior  
     Headlamps, HID (High-Intensity Discharge) / 12  
     Taillamps, LED (Light-Emitting Diode) / 12  
 LATCH (Lower Anchors and Tethers for Children) System / 19, 23

Liftgate  
     Appliqué, Satin Aluminum / 12  
     Power / 7  
 Lighting, Ambient Interior / 6, 9, 12, 14  
 Maintenance  
     Accessory Drive Belt / 24  
     Oil Change Interval / 24  
     Spark-plug 90,000-mile / 24  
     Transmission Fluid / 24  
 Navigation System, Voice-activated with SIRIUS Travel Link™ / 6, 8, 11, 26  
 Noise, Vibration, and Harshness (NVH) / 24  
 Packages  
     Class III Trailer Tow Package / 18  
     Convenience Package / 10  
     Lighting Package / 10  
 Pedals, Power Adjustable Accelerator and Brake / 9  
 Personal Safety System® / 19, 22  
 Remote Keyless Entry System with Integrated Keyhead Transmitter / 9  
 Reverse Sensing System / 7  
 Roadside Assistance, 24-Hour / 23, 24  
 Roof  
     Multi-panel Vista Roof™ / 6, 8, 12, 14  
     Two-tone / 12  
 Safety Canopy® System with Rollover Sensor / 19, 22  
 Seating  
     40/40 Auto-fold Second-row / 6  
     Command Seating™ / 10  
     Head Restraints, Adjustable / 10  
     Seatbacks, Fold-flat / 10  
     Second-row / 10  
     Three rows / 6  
     Third-row / 10  
 SOS Post Crash Alert System / 19  
 Steering, Rack-and-Pinion / 15, 18  
 Styling, Exterior / 12, 13  
 Styling, Interior / 12, 14  
 Suspension  
     Front Independent MacPherson Strut / 15, 17  
     Rear Independent Multi-link Suspension / 15, 17  
 Tire Pressure Monitoring System (TPMS) / 19, 22  
 Towing / 15  
 Traction Control, All-Speed / 19, 20  
 Transmission, 6-speed Automatic / 16  
 Warranty  
     New Vehicle Limited / 24  
     Powertrain Limited / 24  
 Wheel Arches, Pronounced / 12

## WHAT'S IMPORTANT

### This page is about:

- Key Messages
- The Crossover Segment
- The Flex Customer
- Key Competitors

# 2009 Flex

## What's Important

### Overview

#### Key Messages

##### FLEX



- The all-new 2009 Flex is the latest 7-passenger entry into the growing crossover segment
- The daring design, excellent interior comfort, advanced technology and safety features set Flex apart from the competition
- Flex delivers a balance of car-like ride and handling without sacrificing style, comfort, storage or capability
- Flex appeals to customers who demand style with their substance

### The Crossover Segment

Crossovers are the latest and one of the fastest-growing vehicle segments in the automotive industry, and Flex is Ford's all-new 7-passenger entry. While there is no universal definition, a crossover is a vehicle that combines the best features of a car with the capability of an SUV. But some crossovers remain too close to their car or SUV roots. The all-new Flex is the crossover with a balance of car-like performance and agility without the sacrifice of SUV-like comfort and capability. Consider these features when describing Flex as a crossover vehicle:

#### Car-like attributes:

- Quality fit and finish
- Quiet interior
- Smooth ride and nimble performance
- Maneuverability
- Responsive handling
- Easy to get in and out of
- Good fuel economy

#### SUV attributes:

- Comfortable seating for up to 7 passengers
- Flexible seating configurations
- Standard towing capability of 2000 lbs. and 4500 lbs. with the Trailer Tow Package
- Cargo-carrying capability
- Liftgate provides easy access to the rear cargo area
- All-Wheel-Drive capability

### The Flex Customer

Flex will attract customers looking for something fresh and daring. They are discerning, constantly search for the next great challenge and avoid the norm at all cost. Many of these customers may be new to Ford as they seek to replace their traditional sedan, crossover or SUV with the all-new Flex.



#### Key Competitors

- **GMC Acadia** is positioned as the "Professional Grade" crossover with sophistication and style
- **Honda Pilot** is positioned as a true SUV from Honda; it has traditional SUV styling and capability
- **Toyota Highlander** is a smooth, quiet vehicle with conservative, traditional SUV styling

NOTE: See the latest Dealer Ordering Guide for feature availability.

# 2009 Flex

## What's Important

**WHAT'S IMPORTANT**

**This page is about:**

Product Highlights

### Product Highlights

#### FLEX KEY FEATURES

**Daring Design — Inside and Out**  
(pg. 12)

**Available All-Wheel Drive**  
(pgs. 15, 16, 18)

**First-in-class<sup>(1)</sup>  
Easy Fuel™ capless  
fuel filler system**  
(pgs. 6, 7)



**Six standard airbags**  
(pg. 19)

**AdvanceTrac® with RSC®  
(Roll Stability Control™)**  
(pgs. 19, 20)

**Voice-activated  
Navigation System with  
Sirius® Travel Link™**  
(pgs. 6, 8, 11, 26)

**Class-exclusive<sup>(1)</sup>  
second-row  
refrigerated console**  
(pgs. 6, 8)

#### Comfort/Convenience

- First-in-class<sup>(1)</sup> Easy Fuel™ capless fuel filler system
- SecuriCode™ Next Generation Keyless Entry Keypad
- Multi-panel Vista Roof™
- Power liftgate
- Reverse Sensing System
- 6- or 7-passenger seating
- Command Seating™ with front bucket seats
- Second-row 60/40 split bench (3-passenger) or 40/40 auto-fold (2-passenger) seats
- Second-row footrests
- Third-row fold-in-floor 50/50 split bench seat
- Fold-flat seatbacks for all passenger seats
- Power adjustable accelerator and brake pedals
- Class-exclusive<sup>(1)</sup> second-row refrigerated console
- 110-volt inverter (power point outlet)
- Ambient interior lighting
- Sony® premium audio system with 390 watts of power and 12 premium speakers
- Ford SYNC®
- Voice-activated Navigation System with SIRIUS® Travel Link™
  - Rear View Camera
  - 10 GB Music Jukebox
- SIRIUS Satellite Radio
- DVD Entertainment System

#### Design/Styling

- 3-series lineup: SE, SEL and Limited
- Signature tri-bar chrome grille
- HID (High-Intensity Discharge) headlamps
- Grooves in the side panels and liftgate
- Chrome exterior door handles, beltline, mirror caps and fog lamp bezels
- 18- and 19-inch aluminum wheels
- Integrated rocker panel design
- Satin aluminum tailgate appliqué with grooves
- LED (Light-Emitting Diode) taillamps
- Two-tone roof
- Ice Blue backlighting for the interior controls
- Chrome interior door handles, door panel trim, shifter handle insert and vent surrounds
- Satin silver center stack and steering-wheel accents

#### Performance/Handling

- Duratec 35 - 3.5L DOHC V6 engine with 262 horsepower and 248 lb.-ft. of torque
- 6-speed automatic transmission
- Front-wheel drive or available All-Wheel Drive
- Independent MacPherson strut front suspension
- Independent multi-link rear suspension
- Large four-wheel disc brakes
- Rack-and-pinion steering

#### Safety/Security

- Flex received the highest 5-star ratings in all tests performed by NHTSA<sup>(2)</sup>
- Six standard airbags
  - Dual-stage front airbags
  - Front-seat side airbags
  - Safety Canopy® System with rollover sensor
- AdvanceTrac® with RSC® (Roll Stability Control™)
- Anti-lock Braking System (ABS)
- Personal Safety System® with Front Passenger Sensing System
- SOS Post Crash Alert System
- LATCH (Lower Anchors and Tethers for CHildren) System
- Adjustable head restraints
- Rear-door child safety locks
- SecuriLock® passive anti-theft system
- Tire Pressure Monitoring System (TPMS)

#### Quality/Reliability/ Durability

- Solid unibody construction
- 6-month/7,500-mile oil change interval
- Spark plugs rated for 90,000 miles<sup>(3)</sup>
- Duratec self-adjusting accessory drive belt is rated for 150,000 miles<sup>(3)</sup>
- 5-year/60,000-mile Powertrain Limited Warranty and Roadside Assistance Program

(1) Class is large CUVs.

(2) Star ratings are part of the U.S. Department of Transportation's Safercar.gov program ([www.safercar.gov](http://www.safercar.gov)).

(3) Under normal driving conditions.

**NOTE:** See the latest Dealer Ordering Guide for feature availability.

# 2009 Flex Model Lineup

## Model Lineup Pages

The Model Lineup pages are based on the Dealer Ordering Guide and are designed to show key features/equipment on that model. As you move through the model lineup, each model adds to or upgrades the equipment of the preceding model, except where additions/exemptions are noted. The Flex is available in 3 models:

- SE (standard model)
- SEL
- Limited

### SE — Standard model



#### Comfort/Convenience

- Accessory delay
- Audio — AM/FM stereo/single-disc CD/MP3 capability with 6-speaker system
- Auto headlamps — windshield wiper activated
- Auxiliary audio input jack
- Auxiliary climate control
- Battery Saver
- Center stack — cockpit integrated display (compass, driver/passenger temp, outside temp and audio info)
- Climate control
  - Single-zone air conditioning with second-row ducts
  - Rear auxiliary climate control
- Coat hooks (2), second row
- Console:
  - Front-row center with armrest, storage, two cup holders and rear pull-out drawer with storage and two cup holders for second-row passenger use
  - Overhead with map lights and sunglasses holder
- Cruise control
- Cup holders/bottle holders (up to 10)
- Defroster — rear window
- Door locks — power with Autolock
- Easy Fuel™ capless fuel filler system
- Floor mats — carpeted, first and second rows

- Glass, privacy — second row, third row and liftgate
- Glove box — locking, damped
- Grab handles — (3) retractable roof-mounted
- Grocery bag hooks in cargo area
- Horn
- Illuminated entry
- Instrumentation (tachometer, TPMS indicator, lamp outage, low washer fluid, low oil pressure, oil change, door ajar, liftgate ajar & low coolant indicator)
- Lights:
  - Cargo area over third row
  - Reading lamps for second- and third-row passengers
- Map pockets — front seatback
- Message center with trip computer
- Mirror, rearview — electrochromic auto-dimming
- Power door locks and mirrors
- Power points — (4) 12-volt
- Power windows with one-touch up/down driver window
- Remote Keyless Entry with two integrated keyhead transmitters
- Reverse Sensing System
- Seats:
  - 7-passenger (3 rows of seating)
  - Second-row 60/40 cloth split bench
  - Third-row 50/50 cloth split bench, fold-in-floor
  - Driver, 6-way power with manual recline and lumbar
  - Dual front-row cloth bucket seats
  - Passenger, 2-way manual recline
  - All passenger seats — fold-flat seatbacks
- SecuriCode™ Next Generation Keyless Entry Keypad

- Shift knob — leather-wrapped
  - Steering column — tilt adjustable, manual
  - Steering wheel:
    - Leather-wrapped
    - Audio and cruise controls
  - Storage:
    - Front floor console bin
    - Instrument panel storage bin
    - Integrated door storage (pockets), first and second rows
  - Sun visors — sliding driver and passenger with illuminated vanity mirrors
  - Windshield wipers:
    - Front, intermittent speed-sensitive
    - Rear, 2-speed
- #### Design/Styling
- Black beltline
  - Chrome HVAC vent surrounds, shifter handle, door trim and door handles
  - Door handles, exterior — painted body-color
  - Exhaust tips — bright polished stainless steel
  - Fog lamps — painted body-color bezel
  - Grille — chrome tri-bar
  - Grooves — side panel and liftgate
  - Mirrors — black, power, manual folding
  - Wheels — 18-inch painted aluminum

#### Performance/Handling

- Brakes — 4-wheel disc
- Engine — 3.5L V6 Duratec engine
- Spare tire, mini
- Steering — rack-and-pinion
- Tires — P235/60R18 BSW
- Transmission — 6-speed automatic

#### Safety/Security

- Adjustable head restraints
- AdvanceTrac® with RSC® (Roll Stability Control™)
- Airbags:
  - First-, second- and third-row Safety Canopy® System with rollover sensor
  - Dual-stage front airbags
  - Front-seat side airbags
- Anti-lock Braking System (ABS)
- Belt-Minder® System (driver and front passenger)
- Child safety locks — rear door
- Front Passenger Sensing System
- LATCH (Lower Anchors and Tethers for Children)
- Perimeter anti-theft system
- Personal Safety System®
- SecuriLock® passive anti-theft system
- SOS Post Crash Alert System
- Tire Pressure Monitoring System (TPMS)

#### Quality/Reliability/Durability

- Fuel tank — 18.6-gallon

**NOTE:** The above information is an excerpt to be used with pages 1–3 of the 8/15/08 Flex Dealer Ordering Guide. For the latest Dealer Ordering Guide go to [fmcdealer.com](http://fmcdealer.com)

# 2009 Flex Model Lineup

## MODEL LINEUP

This page is about:

SEL —

Limited —

Optional Equipment —

### SEL — All SE content, plus:



#### Comfort/Convenience

- Air conditioning — Dual-zone Electronic Automatic Temperature Control
- Audio — Sony® premium AM/FM stereo/6-disc in-dash CD/MP3 capability with SIRIUS® Satellite Radio
- Cargo net

- Leather-trimmed seats with contrast stitching:
  - First row, heated
  - Driver, 10-way power
  - Passenger, 6-way power with manual lumbar
  - Third-row seat is vinyl
- Universal garage door opener

#### Design/Styling

- Chrome beltline
- Chrome door handles
- Chrome fog lamp bezels
- LaCrosse Ash woodgrain appearance appliqué on instrument panel and door trim
- Mirrors — body-color, heated manual fold
- SEL badge
- Wheels — 18-inch machined aluminum

### Limited — All SEL content, plus:



#### Comfort/Convenience

- 110-volt inverter (power point outlet)
- Ambient interior lighting
- Analog clock
- Footrests — second-row
- Ford SYNC®
- Mirrors — folding power, heated with memory and security approach lamps
- Power adjustable pedals with memory
- Power liftgate

- Seats
  - Perforated leather seating surfaces with contrast stitching (3rd-row vinyl)
  - First-row memory
- Steering wheel with real-wood inlay

#### Design/Styling

- Chrome door sill scuff plates
- HID (High-Intensity Discharge) headlamps
- LED (Light-Emitting Diode) taillamps

- LIMITED badge
- Mirrors — chrome caps
- Olive Ash Copper woodgrain appearance appliqué on instrument panel and door trim
- Satin aluminum liftgate appliqué with grooves
- Wheels — 19-inch polished aluminum
- Tires — P235/55R19 BSW

**NOTE:** The above information is an excerpt to be used with pages 1–3 of the 8/15/08 Flex Dealer Ordering Guide. For the latest Dealer Ordering Guide go to [fmcdealer.com](http://fmcdealer.com)

## Ordering Made Easy

Ford has developed Fast Turn Orders (FTOs) based upon extensive analysis of dealer sales performance and the fastest turning vehicle configurations. Suggested FTOs are available within the Flex Dealer Ordering Guide.

## Optional Equipment

	SE	SEL	Limited
<b>Comfort/Convenience</b>			
All-weather floor mats	O	O	O
AM/FM 6-disc CD/MP3 capable with SIRIUS® Satellite Radio and 6 speakers	O	—	—
Convenience Package	—	O	S
Lighting Package	—	O	S
DVD Entertainment System	—	O	O
Floor console, second row (only applicable with second-row 40/40 bucket seats, 6-passenger)	—	O	O
Ford SYNC® voice-activated digital communications and entertainment system <sup>(1)</sup>	O	O	S
Multi-panel Vista Roof™	—	O	O
Voice-activated Navigation System with SIRIUS Travel Link™ and Rear View Camera (late availability on SEL)	—	O	O
Power Code™ Remote Start System	O	O	O
Seating, second-row 40/40 auto-fold reclining seats with cloth trim (6-passenger seating)	O	O	—
Seating, second-row 40/40 auto-fold reclining leather-trimmed seats with contrast stitching and fore/aft adjustment	—	O	—
Seating, second-row 40/40 auto-fold heated reclining perforated leather-trimmed seats with contrast stitching and fore/aft adjustment	—	—	O
Second-row refrigerated console (requires 2nd-row console)	—	O	O
<b>Design/Styling</b>			
Roof, two-tone	—	O	O
Roof rack side rails (N/A w/ Vista Roof)	O (Black)	O (Chrome)	O (Chrome)
17-inch aluminum wheels with P235/60R17 BSW tires (available in snow states only)	O	—	—
20-inch bright painted aluminum (late availability)	—	O	O
<b>Performance/Handling</b>			
Trailer Tow Package, Class III (Fall 2008 on FWD models)	O	O	O

S = Standard O = Optional — = Not Available

(1) Driving while distracted can result in loss of vehicle control. Only use mobile phones, navigation systems and other devices, even with voice commands, when it is safe to do so.

**NOTE:** The above information is an excerpt to be used with page 5 of the 8/15/08 Flex Dealer Ordering Guide.

For the latest Dealer Ordering Guide go to [fmcdealer.com](http://fmcdealer.com)

July 2008

# 2009 Flex

## Comfort/Convenience

**This page is about:**

- Seating
- Class-exclusive Second-row Refrigerated Console
- Voice-activated Navigation System with SIRIUS® Travel Link™
- Ford SYNC®
- First-in-class Easy Fuel™ Capless Fuel Filler System
- Multi-panel Vista Roof™

### Overview

#### Key Messages

**Flex**

- Seating for 6 or 7 passengers
- Best-in-class<sup>(1)</sup> limousine-like second-row room with adjustable and removable footrests and over 7 inches more leg room than the 2008 GMC Acadia
- First-in-class<sup>(1)</sup> Easy Fuel™ capless fuel filler system
- Second-row refrigerated console
- Ford SYNC® connects audio and phone technology to the vehicle sound system<sup>(2)</sup>
- Voice-activated Navigation System with SIRIUS® Travel Link™ also features a Rear View Camera and 10 GB Music Jukebox
- Reverse Sensing System

#### Key Features

##### Seating

**Seating for 6 or 7 passengers** with limousine-like leg room for second-row passengers.

**Three rows of seating** with adjustable head restraints for all seating positions and a third-row split bench seat that folds flat into the floor.



**40/40 auto-fold second-row bucket seats** provide one-touch folding operation for access to the third-row seats and include fore/aft adjustment for optimum leg room. Flex seats 6 passengers with the 40/40 seats.



**Fold-flat seatback for all passenger seats** provides cargo-carrying flexibility with nearly 10 ft. of cargo length from the instrument panel to the tailgate.



##### Interior

**Class-exclusive<sup>(1)</sup> second-row refrigerated console** operates similarly to a home refrigerator, has cool and freeze modes and keeps up to seven 12 oz. beverages cold on a long trip.



**Voice-activated Navigation System with SIRIUS Travel Link** includes a Rear View Camera, 10 GB Music Jukebox and an easy-to-use 8-inch LCD touch screen.<sup>(2)</sup> SIRIUS Travel Link provides traffic and weather updates, fuel prices, sports updates and movie listings.<sup>(3)</sup>



**Ford SYNC** is a fully integrated voice-activated in-car communications and entertainment system for Bluetooth enabled<sup>®</sup>,<sup>(4)</sup> mobile phones and most digital music players.<sup>(2)</sup>

**Ambient interior lighting** allows the choice of seven different colors to illuminate the first- and second-row footwells, front console cup holders, front console armrest storage and the second-row lower storage drawer/cup holders located at the rear of the front console.

**DVD Entertainment System** with 8-inch LCD screen keeps rear-seat passengers entertained.



##### Exterior

**First-in-class<sup>(1)</sup> Easy Fuel™ capless fuel filler system** eliminates the need for a fuel filler cap and helps make fill-ups easier — no more hassle of fumbling with a fuel filler cap.



**Multi-panel Vista Roof™** brightens the interior and gives front-seat passengers a power moonroof and second- and third-row passengers their own personal skylight, all with manual sunshades.



(1) Class is large CUVs.

(2) Driving while distracted can result in loss of vehicle control. Only use mobile phones, navigation systems and other devices, even with voice commands, when it is safe to do so.

(3) Real-time traffic monitoring available in select markets. Some features may not be available while the vehicle is in motion. Service not available in Alaska or Hawaii. SIRIUS is a registered trademark of SIRIUS Satellite Radio, Inc.

(4) The Bluetooth word mark and logos are trademarks of the Bluetooth, SIG, Inc.

# 2009 Flex

## Comfort/Convenience

### COMFORT/CONVENIENCE

#### This page is about:

- First-in-class Easy Fuel™ Capless Fuel Filler System
- Power Liftgate
- Reverse Sensing System
- SecuriCode™ Next Generation Keyless Entry Keypad

## Exterior Features

### First-in-class<sup>(1)</sup> Easy Fuel™ Capless Fuel Filler System

- **Fill-ups are easier and quicker** since there is no need for a fuel filler cap
- A standard-size unleaded fuel nozzle inserts directly into the filler neck, opening a spring-loaded door to the tank
- **No more dirty hands** since there is no cap to fumble with and a rubber seal on the fuel filler door helps keep dirt from entering the Easy Fuel system
- **Helps reduce fuel tank evaporative emissions** by eliminating the potential for customers to drive off with a missing or improperly installed gas cap
- An emergency funnel is included and is *required* to properly open the Easy Fuel system to accept fuel from a gas can or other secondary refueling device. The funnel is stored near the spare tire jack. See the vehicle Owner's Guide for more information
- For additional security, there's a locking fuel filler plug available from Ford Accessories



### PRESENTATION TIP: Easy Fuel™ Capless Fuel Filler System

Be sure to fully understand the functionality of the Easy Fuel capless fuel filler system and present the benefits during a demonstration drive and at delivery. Show the customer how it's different than a traditional system, including the fuel door seal. In addition, be sure to show the customer where the emergency funnel is located in the vehicle — it is stored near the spare tire jack — since the funnel is required for the customer to add fuel from a portable container.

### Power Liftgate

- Open or close the liftgate with the touch of a button on the instrument panel or on the integrated keyhead transmitter
- Liftgate can also be opened by the button under the liftgate handle and closed by the button inside the cargo area
- Provides functionality and convenience by making it easier to load and unload cargo
- Message center includes a liftgate enable/disable function
- For additional safety, the liftgate will reverse the opening or closing motion if an obstacle is detected

### Reverse Sensing System

- Automatically alerts the driver with an audible tone to certain objects up to 6 feet behind the vehicle
- Audible tone increases in frequency as vehicle nears an object until it becomes a continuous tone when the vehicle is less than 10 inches from the object
- Very helpful when parallel parking, slowly backing up or hitching a trailer

### SecuriCode™ Next Generation Keyless Entry Keypad

- A light touch or tap of the keypad area backlights the keypad for use
- Smooth button interface and backlighting feature make the keypad "invisible" when not in use
- Located on the driver's-door B-pillar
- Unlocks the driver's door and/or all four doors and unlocks the liftgate without a key by using a programmable 5-digit code
- Pressing the 7/8 and 9/0 buttons at the same time locks the vehicle
- Owner can program up to three individual 5-digit codes
- Can also be programmed for memory settings of power seats, mirrors and adjustable pedals (if equipped)



(1) Class is large CUVs.

## COMFORT/CONVENIENCE

### This page is about:

- Class-exclusive Second-row Refrigerated Console
- Multi-panel Vista Roof™
- 110-volt Inverter (Power Point Outlet)
- Voice-activated Navigation System with SIRIUS® Travel Link™
- Front Console

# 2009 Flex

## Comfort/Convenience

### Interior Features

#### Class-exclusive<sup>(1)</sup> Second-row Refrigerated Console

- Refrigerated compartment keeps up to (7) 12-ounce cans, (4) half-liter or (2) 20-ounce beverages cold on a long trip in a unit with 5.5 liters of volume
- Accessed via a forward-opening lid in the rear center console
- Compressor-driven system is self-contained in the rear console, functions similar to a home refrigerator and is designed to be more efficient than thermoelectric or air conditioner-based systems found in other vehicles
- Functions when the vehicle is in Run or Start mode
- Three modes:
  - **Off Mode**
  - **Cool Mode** is designed to keep the unit at 41 degrees Fahrenheit/5 degrees Celsius
  - **Freeze Mode** is designed to keep the unit at 23 degrees Fahrenheit/-5 degrees Celsius

#### PRESENTATION TIP: Second-row Refrigerated Console

Be sure to familiarize customers with Flex's available second-row refrigerated console. This system will be a favorite with passengers. Get to know the location and functionality of the refrigerated console and be able to demonstrate the Cool Mode and Freeze Mode. And be sure to explain that the refrigerated console is a compressor-driven system similar to a home refrigerator. You just can't beat filling the Flex refrigerated console up with some beverages and they'll stay cold for the long drive.

#### Multi-panel Vista Roof™

- Power moonroof for front-seat passengers
- Two fixed glass skylights for second-row passengers
- Single fixed glass skylight for third-row passengers
- Manual sunshades for moonroof and skylights

#### 110-volt Inverter (Power Point Outlet)

- Designed to power laptops, mobile phones, etc., with a household-style outlet
- Provides power while the engine is running or while the ignition is in the Run position
- Located in the rear of the front console
- Includes "plug and turn" engagement feature and a cover for safety
- Overload protected

#### Voice-activated Navigation System with SIRIUS® Travel Link™

- Includes a single-disc version of the Sony® Premium Audio System
- Control the system via the 8-inch LCD touch screen or with certain **voice commands** that allow hands-free operation of the system<sup>(2)</sup>
- **SIRIUS Travel Link** capability provides real-time traffic and weather updates, fuel pricing, sports scores and movie listings.<sup>(3)</sup> Includes 6-month complimentary subscription subject to location and availability
- **10 GB Music Jukebox capability** allows for storage and access to around 2,400 songs
- **Upload photos** or watch a DVD while vehicle is in park
- **Turn-by-turn voice directions** include street name pronunciations
- **Emergency button** provides nearest emergency facility to choose as a destination (hospital or police)
- Includes **integrated climate control** functions
- **Rear View Camera System** includes a camera located in the liftgate that provides added driver convenience when backing up and is especially useful when parallel parking or hitching a trailer
  - System automatically engages when the vehicle is placed in Reverse
  - Video is shown on the Navigation System screen with an image providing vehicle centerline, rear bumper orientation and green, yellow and red trajectory lines to relate an object's proximity to the rear of the vehicle

#### Front Console

- Auxiliary audio input jack
- Two cup holders for front-seat passengers next to the shifter handle
- Auxiliary 12V power point for second-row passengers
- Coin holder and CD storage inside console
- Pull-out storage bin and cup holders for second-row passengers located in the lower back of the first-row console



(1) Class is large CUVs.

(2) Driving while distracted can result in loss of vehicle control. Only use navigation systems and other devices, even with voice commands, when it is safe to do so.

(3) Real-time traffic monitoring available in select markets. Some features may not be available while the vehicle is in motion. Service not available in Alaska or Hawaii. SIRIUS is a registered trademark of SIRIUS Satellite Radio, Inc.

# 2009 Flex

## Comfort/Convenience

### COMFORT/CONVENIENCE

#### This page is about:

- Ambient Interior Lighting
- Second-row Console
- Rear Auxiliary Climate Control
- Dual-zone Electronic Automatic Temperature Control
- Remote Keyless Entry System with Integrated Keyhead Transmitter
- Power Adjustable Accelerator and Brake Pedals

## Interior Features cont'd

### Ambient Interior Lighting

- Illuminates:
  - First- and second-row footwells
  - Front console cup holders
  - Front console storage bin
  - Second-row lower storage drawer/cup holders located at the rear of the front console
- Choice of aqua, blue, green, purple, red, white and yellow as a color
- Control switch is located under the armrest in the front center console

### Second-row Console

- Includes two cup holders and a storage bin
- Center armrest opens in a forward motion to provide access to the storage bin
- Forward opening armrest design also provides a flat loadfloor combined with the fold-flat seatbacks
- Is available only with the 40/40 second-row seats and provides 6-passenger seating
- Second-row console and refrigerated second-row console are separate features

### Rear Auxiliary Climate Control

- Provides additional heating and cooling components, rear vents and rear controls for second- and third-row comfort
- Controls are located on the back of the front-row floor console

### Dual-zone Electronic Automatic Temperature Control

- A set-and-forget feature
- System automatically maintains the preset temperature settings
- Allows the driver and front passenger to adjust individual temperature settings for personal preferences in a range between 60 degrees and 80 degrees Fahrenheit



### Remote Keyless Entry System with Integrated Keyhead Transmitter

- Replaces the standard key and separate Remote Keyless Entry fob combination with a single integrated keyhead transmitter
- System operates all door and liftgate locks and power liftgate (if equipped) and includes a panic button

### Power Adjustable Accelerator and Brake Pedals

- Can be moved from the standard position to approximately 3 inches closer to the driver
- Includes memory feature on Limited models

### Universal Garage Door Opener

- Operates up to three functions such as opening a security gate, garage door or turning on house lights
- Located on the driver's sun visor

### ENGINEERING INSIGHT

#### Integrated Keyhead Transmitter

The integrated keyhead transmitter is designed so customers won't accidentally activate the panic alarm while inserting or removing the key from the ignition or their pocket. To avoid any confusion or unnecessary repair visits, review these features with your customers:

- Lock/unlock functions work the same as traditional Ford key fobs
- To activate the panic alarm, press and hold the button for 1.5 seconds or longer
- To use the "car finder" feature, push the Lock button twice in 3 seconds
- Horn will chirp and the vehicle turn signals will flash once

For more details on the recommended handling of the integrated keyhead transmitter, refer to the vehicle Owner's Guide.

# 2009 Flex

## Comfort/Convenience

**This page is about:**

- Command Seating™
- Fold-down Passenger Seatbacks
- Adjustable Head Restraints
- Second-row Seating
- Second-row Footrests
- Third-row Seating

### Seating

#### Command Seating™

- Front bucket seats sit higher than a typical sedan, but lower than an SUV — giving driver and front passenger clear vision in all directions and a more confident position
- Raised seat height helps provide effortless vehicle entry and exit

#### Fold-flat Passenger Seatbacks

- All passenger seatbacks fold flat for cargo-carrying flexibility
- There's up to 10 feet of open pass-through storage from the liftgate to the instrument panel when the front-passenger and second-row seatbacks are folded flat, and third-row seats folded into the floor
- Provides convenient space for transporting long objects

#### Adjustable Head Restraints

- Adjustable head restraints offer driver and passenger comfort when in use and can be lowered for improved visibility when not in use
- Standard for all seating positions

#### Second-row Seating

- Standard 60/40 reclining split bench
- Available auto-fold 40/40 reclining bucket seats provide 6-passenger seating and easy access to the third-row seats with:
  - One-touch folding operation for access to third-row seats
  - Button conveniently located on the C-pillar trim
- Fore/aft adjustable for optimum leg room
- SEL offers leather-trimmed seats
- Limited offers heated, perforated leather-trimmed seats
- Map pockets and bottle holders located in the doors
- Best-in-class<sup>(1)</sup> limousine-like leg room with seven more inches of leg room than the 2008 GMC Acadia

#### Second-row Footrests

- Wedge-shaped design elevates occupants' feet, providing a more comfortable seating position for second-row passengers
- Adjustable and removable
- Exclusive friction hook design allows adjustment to a desired location, or stowage under the driver and passenger front seats when not in use
- Color-keyed carpet-wrapped design matches the carpeting and provides increased durability

#### Third-row Seating

- 50/50 split bench
- Seats stow by folding flat into the floor, providing a flat-floor cargo area
- Each outboard armrest features an integrated storage bin and cup holder

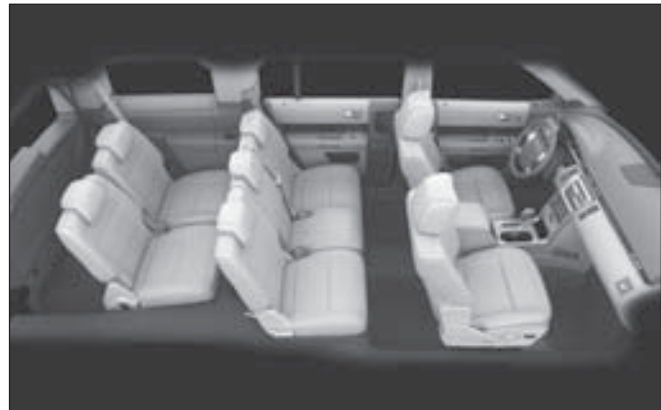

### SEL Packages

Convenience Package	Lighting Package
<ul style="list-style-type: none"> <li>• Power adjustable pedals with memory</li> <li>• Power liftgate</li> <li>• Memory driver's seat and sideview mirrors</li> <li>• Security approach lamps</li> <li>• 110-volt inverter (power point outlet)</li> </ul>	<ul style="list-style-type: none"> <li>• Ambient interior lighting</li> <li>• HID (High-Intensity Discharge) headlamps</li> <li>• LED (Light-Emitting Diode) taillamps</li> </ul>

(1) Class is large CUVs.

# 2009 Flex

## Comfort/Convenience

### COMFORT/CONVENIENCE

#### This page is about:

- Audio Systems —
- SIRIUS® Satellite Radio —
- DVD Entertainment System —
- Ford SYNC® —
- Voice-activated Navigation System with SIRIUS® Travel Link™ —
- SIRIUS Travel Link —

## Audio/Entertainment Systems

### Audio Systems

- AM/FM stereo/single-disc CD/MP3 capability 6-speaker system
- AM/FM stereo/6-disc CD/MP3 capability with SIRIUS® Satellite Radio and 6 speakers
- Sony® Premium AM/FM stereo/6-disc In-dash CD/MP3 capability with SIRIUS® Satellite Radio and 12 speakers
- See page 25 for more information

### SIRIUS® Satellite Radio

- Over 130 channels
- Commercial-free music
- Digital sound quality
- Seamless coverage anywhere in the contiguous U.S.
- 6-month complimentary subscription<sup>(1)</sup> subject to location and availability
- See page 27 for more information

### DVD Entertainment System

- 8-inch LCD screen folds down from the center of the headliner
- Dual-media feature allows front passengers to enjoy the audio system while rear passengers watch a movie
- Includes two sets of wireless headphones and remote control
- Universal audio/video jacks for video gaming systems or a camcorder
- See page 27 for more information

### Ford SYNC®

Ford and Microsoft® have teamed up to develop Ford SYNC.<sup>(2)</sup> This Ford exclusive technology will change the way customers use their digital media and Bluetooth<sup>®(3)</sup> wireless technology enabled mobile phones. SYNC allows drivers to stay connected to the information, entertainment and people they care about while on the road. SYNC features:

- Voice-activated hands-free calling
  - Uninterrupted connections that allow going directly from mobile phone to the vehicle's hands-free phone during the call
  - Audible text messages
  - Advanced calling features like caller ID, call waiting, conference calling and more
  - Voice-activated control of an MP3-style media player
  - Instant voice recognition
  - Ringtone support
  - Automatic phone book transfer for mobile phones with this feature
  - Multilingual intelligence (English, French, Spanish)
- For more information, go to [www.syncmyride.com](http://www.syncmyride.com).

### Voice-activated Navigation System with SIRIUS® Travel Link™

- 8-inch LCD touch-screen display
- Real-time traffic and weather reports provided by SIRIUS Travel Link
- 10 GB Music Jukebox for storage and access to around 2,400 songs
- Integrated climate control functions
- Rear View Camera displays on the LCD screen
- Fast route calculations, zooming, scrolling and route previews
- Audible step-by-step route guidance feature that announces upcoming maneuver with specific street names
- Capable of playing DVD-based movies while vehicle is in Park
- Includes Sony® Single DVD/CD/MP3 capable audio system
- See page 26 for more information

### SIRIUS Travel Link™<sup>(2, 4)</sup>

- Real-time traffic updates every 2.5 minutes and includes automatic rerouting capability
- Weather updates provide current weather and five-day forecast
- Fuel pricing for over 120,000 gas stations
- Sports updates and movie listings
- 6-month complimentary subscription subject to location and availability<sup>(1)</sup>
- See page 26 for more information

(1) SIRIUS Satellite Radio and SIRIUS Travel Link are separate subscriptions.

(2) Driving while distracted can result in loss of vehicle control. Only use mobile phones, navigation systems and other devices, even with voice commands, when it is safe to do so.

(3) The Bluetooth word mark and logos are trademarks of the Bluetooth, SIG, Inc.

(4) Real-time traffic monitoring available in select markets. Some features may not be available while the vehicle is in motion. Service not available in Alaska or Hawaii. SIRIUS is a registered trademark of SIRIUS Satellite Radio, Inc.

## DESIGN/STYLING

### This page is about:

- Unique Greenhouse and Horizontal Grooves
- Satin Aluminum Liftgate Appliqué
- SecuriCode™ Next Generation Keyless Entry Keypad
- Two-tone Roof
- Premium Fit and Finish
- Multi-Panel Vista Roof™

# 2009 Flex

## Design/Styling

## Overview

### Key Messages



- Daring design with a confident stance and horizontal grooves on the side panels and liftgate
- 18- and 19-inch aluminum wheel designs
- Integrated rocker panel design makes getting in and out easy
- Three distinct models — SE, SEL and Limited
- Multi-panel Vista Roof™ provides personal open-air enjoyment and skylight ambiance for all passengers
- HID (High-Intensity Discharge) headlamps and LED (Light-Emitting Diode) taillamps provide a distinctive look and increased lighting performance

### Key Features

#### Daring Design — Outside

**Signature tri-bar chrome grille** builds on the family “face” of Ford and gives a look of elegant sophistication.

**Unique greenhouse** describes the windshield, side and rear windows, and pillars separating the glass. The roof and body of Flex are seamlessly tied together with a black window pillar treatment and privacy glass on all windows behind the B-pillar.

**Horizontal grooves** on the side panels and liftgate give Flex a modern appearance from the profile and provide a sense of motion.

**Satin aluminum liftgate appliqué** echoes the clean lines of the bold tri-bar grille and includes the horizontal grooves.

**SecuriCode™ Next Generation Keyless Entry Keypad** is located on the B-pillar and features “touch-sensing” backlighting and smooth interface for the buttons — making the keypad “invisible” when not in use.

**Two-tone roof** is available in White Suede or Brilliant Silver for a personalized styling statement. Monotone roof is standard in all exterior colors.

**Integrated rocker panel design** helps make getting in and out of the vehicle easier.

**Pronounced wheel arches** add to competent stance and give presence to the striking wheel designs.

**HID (High-Intensity Discharge) headlamps** provide a distinctive look and excellent nighttime visibility. HID lamps are also designed to last longer and produce more light than halogen headlamps.

**LED (Light-Emitting Diode) taillamps** illuminate faster, require less power and last longer than traditional bulbs.

#### Daring Design — Inside

**Premium fit and finish** with tight tolerances, soft-touch surfaces throughout and the use of complementing materials and colors give the interior a finely finished look.

**Sophisticated instrument panel** includes satin aluminum accents and provides excellent readability and ergonomic placement of controls.

**Analog clock** is carefully placed in the center console, beautiful in appearance and simply elegant in function.

**Ambient interior lighting** illuminates the interior in a choice of aqua, blue, green, purple, red, white or yellow LED lighting.

**Multi-panel Vista Roof** provides a power moonroof over the front-seat passengers and skylights over the second and third rows. Also features manual sunshades for all three rows.



# 2009 Flex

## Design/Styling

### DESIGN/STYLING

This page is about:

Exterior Distinctions

Exterior Colors

## Exterior Distinctions

### Exterior Distinctions — SE

- Door handles — painted body-color
- Fog lamps — painted body-color bezel
- Mirrors — black, power, manual folding
- Wheels — 18-inch painted aluminum

### Exterior Distinctions — SEL

- Chrome beltline
- Door handles — chrome
- Fog lamps — chrome bezel
- Mirrors — body-color, heated manual fold
- SEL badge
- Wheels — 18-inch machined aluminum

### Exterior Distinctions — Limited

- HID (High-Intensity Discharge) headlamps
- LED (Light-Emitting Diode) taillamps
- Limited badge
- Satin aluminum liftgate appliqué
- Mirrors — chrome caps, folding power heated
- Wheels — 19-inch polished aluminum



## Exterior Colors

### Exterior Colors

- Black Clearcoat (UA)
- Brilliant Silver Clearcoat Metallic (UI)
- Cinnamon Clearcoat Metallic (HT)
- Dark Ink Blue Clearcoat Metallic (DI)
- Light Ice Blue Clearcoat Metallic (LS)
- Redfire Clearcoat Metallic (G2)
- Sterling Grey Clearcoat Metallic (UJ)
- White Platinum Tri-coat — SEL and Limited only (UG)
- White Suede Clearcoat (WS)

### Exterior Colors with White Suede Two-Tone Roof

- Brilliant Silver Clearcoat Metallic (UI)
- Cinnamon Clearcoat Metallic (HT)
- Dark Ink Blue Clearcoat Metallic (DI)
- Light Ice Blue Clearcoat Metallic (LS)
- Redfire Clearcoat Metallic (G2)
- Sterling Grey Clearcoat Metallic (UJ)

### Exterior Colors with Brilliant Silver Two-Tone Roof

- Black Clearcoat (UA)
- White Suede Clearcoat (WS)

**This page is about:**

- Multi-panel Vista Roof™
- Ambient Interior Lighting
- Interior Distinctions
- Interior Colors

## Interior

### Multi-panel Vista Roof™

- Brightens the interior and gives Flex front-seat passengers a power moonroof and second- and third-row passengers their own personal skylight
- Two second-row skylights are 17.0 x 11.9 inches each, for a total area of 405.9 square inches
- A single third-row skylight is 12.6 x 32.1 inches, for a total area of 404.1 square inches
- Includes manual sunshades for moonroof and skylight openings



### Ambient Interior Lighting

- LED (Light-Emitting Diode) lights illuminate the first- and second-row footwells, front console cup holders and the front console storage bin and rear-seat climate controls located at the rear of the front console in a choice of seven different colors
- Colors include aqua, blue, green, purple, red, **white** and **yellow**

### Interior Distinctions — SE

- Cloth seating surfaces with “tweed-like” bolsters and houndstooth inserts
- Leather-wrapped steering wheel and shift knob
- Satin Silver center stack and steering-wheel accents
- Chrome HVAC vent surrounds, shifter handle, door trim and door handles
- Ice Blue backlighting for the instrument cluster and interior switches and controls

### Interior Distinctions — SEL

- Leather-trimmed seats with contrast stitching
- LaCrosse Ash woodgrain appearance appliqué on instrument panel and door trim

### Interior Distinctions — Limited

- Perforated leather-trimmed seats with contrast stitching
- Steering wheel with real wood inlay
- Olive Ash Copper woodgrain appearance appliqué on instrument panel and door trim
- Chrome door sill scuff plates

### Interior Colors for All Models

- Dark Charcoal
- Medium Light Stone



# 2009 Flex

## Performance/Handling

### PERFORMANCE/HANDLING

#### This page is about:

- Duratec 35 - 3.5L DOHC V6 engine
- intake-Variable Cam Timing (i-VCT)
- 6-speed Automatic Transmission
- Available All-Wheel Drive (AWD)
- Suspensions
- Rack-and-pinion Steering

## Overview

### Key Messages

#### Flex



- Duratec 35 - 3.5L DOHC V6 engine with 262 horsepower and 248 lb.-ft. of torque
- Wide-ratio 6-speed automatic transmission provides smooth, quiet shifting
- Available All-Wheel Drive helps provide surefootedness in a variety of road conditions
- Fully independent front and rear suspensions provide car-like ride and handling
- Up to 24 EPA-estimated highway mpg (FWD)
- Rated to tow 4500 lbs. when properly equipped with the Class III Trailer Tow Package

### Key Features

#### Powertrain

**Duratec 35 - 3.5L DOHC V6 engine** combines durability and efficiency to deliver 262 horsepower and 248 lb.-ft. of torque.

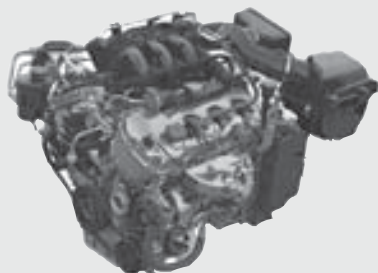

**intake-Variable Cam Timing (i-VCT)** adjusts cam timing to provide optimum performance and fuel economy.

**6-speed automatic transmission** provides smooth, quiet operation with impressive launch and acceleration.

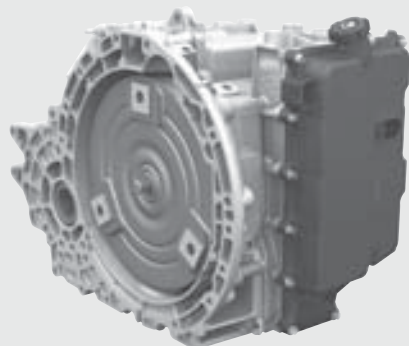

**Available All-Wheel Drive (AWD)** uses an electrohydraulic limited-slip coupling to provide all-weather traction.

#### Suspension and Chassis

**Independent MacPherson strut front suspension** features a coil-over-shock design with an L-shaped lower control arm for an excellent balance of spirited handling and crisp steering response.

**Independent multi-link rear suspension** is built on a stout fully isolated boxed subframe which allows chassis engineers to better tune the suspension components for excellent ride and handling characteristics.



**Rack-and-pinion steering** maintains linear steering effort as the driver turns the wheel, resulting in responsive steering that naturally follows a straight line as the wheel is turned.

**Large four-wheel vented disc brakes** provide excellent braking performance and include an anti-lock braking system (ABS).

#### Towing

**4500-lb. maximum towing capacity** when properly equipped with the Class III Trailer Tow Package.



**This page is about:**

- Duratec 35 - 3.5L V6 Engine
- 6-Speed Automatic Transmission

### Duratec 35 - 3.5L V6 Engine

**Features**

- 262 horsepower @ 6250 rpm
- 248 lb.-ft. of torque @ 4500 rpm
- Requires only 87-octane regular grade fuel to help keep operating costs low
- Strong, lightweight die-cast aluminum block
- Lightweight aluminum cylinder heads have 4 valves per cylinder to help improve performance
- 10.3:1 compression ratio
- Close-coupled catalysts and intake-Variable Cam Timing (i-VCT) help Flex meet Federal Tier 2 Bin 5 and California Ultra Low Emissions Vehicle (ULEV II) tailpipe emissions standards<sup>(1)</sup>
- Intake was designed as a system, all the way from air inlet to the intake valves, to create optimum flow for peak power and to broaden the torque curve
- Forged steel, fully counterweighted crankshaft
- High-temperature cast aluminum alloy pistons with low-friction coating
- Low-maintenance spark plugs are rated for 90,000 miles under normal driving conditions

**intake-Variable Cam Timing (i-VCT)**

- Allows the camshafts to operate the intake valves at different times in the combustion cycle, based on speed and load
- Adjusts cam timing to provide optimum performance and fuel economy
- Outstanding efficiency under low load conditions like idling or highway cruising
- Remarkable power when accelerating

**Powertrain Performance Benefits**

- Mating the Duratec 35 - 3.5L V6 engine to a 6-speed automatic transmission helps optimize performance
- Closely spaced gears of the 6-speed transmission allow the engine to always find its "sweet spot" — the gear that maximizes engine power
- Quick, responsive acceleration

<b>Fuel Economy</b>	<b>City mpg</b>	<b>Highway mpg</b>
Front-Wheel Drive (FWD)	17	24
All-Wheel Drive (AWD)	16	22

### 6-Speed Automatic Transmission

- Every part of this transmission was designed for smooth, quiet operation
- A wide ratio span that provides power on demand for quick acceleration in low-gear situations
- Tall overdrive gear benefits highway fuel economy
- Overdrive cancel with grade assist feature uses smart gear selection to automatically maintain vehicle speed over hilly terrain
- In "low" range, the transmission controller enables engine braking to help with hill descents or other demands
- "Engine braking" is the engine's ability to slow the car when the transmission is in a low gear
- When the accelerator is released, decreasing the flow of fuel to the engine, the engine's speed slows. Logically, the vehicle slows along with it, but the amount and rate of deceleration depends on the selected gear. The lower the gear, the greater the engine braking
- The most common situation in which to employ engine braking is when descending a steep hill. Riding the brakes can cause overheating and fade
- Low maintenance, with "filled-for-life" transmission fluid that also helps contribute to reduced cost of ownership

(1) For more information on Federal and California emissions standards, see the Glossary & Technology section of the 2009 Source Book Appendices.

# 2009 Flex

## Performance/Handling

### PERFORMANCE/HANDLING

This page is about:

Independent MacPherson Strut Front Suspension

Independent Multi-link Rear Suspension

Hydrobushings

## Driving Dynamics

### Independent MacPherson Strut Front Suspension

The MacPherson strut independent front suspension is a proven design that delivers an excellent balance of spirited handling and crisp steering response.

#### Ride and Handling

- The front struts feature a coil-over-shock design with an L-shaped lower control arm
- Each wheel reacts to road irregularities with no effect on the opposite wheel
- Coil-over-shock design locates the shock absorber in the center of the coil spring which reduces offset and allows the spring and shock to move in precision. This also limits twisting or lateral forces that could bind the shock and cause a harsher ride
- Use of high-strength steel combined with coil-over-shock design allows the use of lightweight springs
- Suspension bushings are tuned independently for responsive steering and a smooth ride
- Large bushing at the top of each strut mount helps resist vertical movements from uneven road surfaces and resists side deflection to deliver crisp steering feel
- Hydrobushing at the rear of the L-shaped lower control arm uses oil-filled internal chambers to dampen road forces from passenger compartment
- Outboard-mounted front stabilizer bar provides precise roll control and steering response

#### Compact Design

- Front struts feature a coil-over-shock design that is more compact than double-wishbone front suspensions
- Allows the maximum amount of room in front of the suspension to help improve crash performance
- Provides more room in the engine compartment for powertrain components

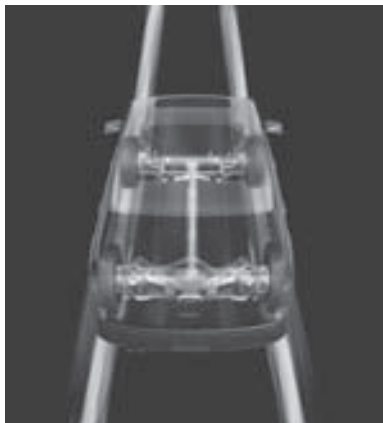

### Independent Multi-link Rear Suspension

Front and rear suspension components are tuned for consistent and balanced shock absorption front to rear, delivering precise handling without the sacrifice of a smooth ride.

#### Strong

- Multi-link design is built on a stout fully isolated boxed subframe
- Shock absorbers are mounted as far outboard as possible — allowing chassis engineers to tune them to handle higher road impacts and deliver an excellent balance of ride and handling
- Independent suspension design lets each wheel react to road irregularities with no effect on the opposite wheel

#### Ride and Handling

- During heavy braking, the suspension causes slight toe-in — which is how much the front part of two opposite wheels point toward the center of the vehicle. This helps enhance steering stability
- Strong foundation allows chassis engineers to better tune the suspension components for excellent ride and handling characteristics

#### PRESENTATION TIP: Hydrobushings

To explain hydrobushing or hydromount vs. solid bushing or mount, use the concept of a water balloon vs. a hockey puck. The hockey puck represents a traditional solid bushing or engine mount.

Have your customer imagine hitting the puck with a solid object like a coffee mug.

- Point out that the puck wouldn't absorb the force from being struck very well
- Solid bushings or mounts, like the solid puck, don't do a very good job of absorbing engine or road vibrations

Next, have them imagine a water balloon as a hydrobushing or hydromount, and doing the same thing.

- The water balloon (hydrobushing or hydromount) absorbs the forces much better than the hockey puck
- So does the liquid-filled bushing or engine mount better absorb road and engine vibrations to keep them from reaching the passenger compartment?

The point will be clear.

**This page is about:**

- Available All-Wheel Drive (AWD)
- Rack-and-pinion Steering
- Four-wheel Disc Brakes
- Electronic Brake Force Distribution (EBD)
- Class III Trailer Tow Package

### Driving Dynamics cont'd

#### Available All-Wheel Drive (AWD)

- AWD is seamless to the driver and provides performance and safety benefits for SEL and Limited
- Continuously monitors vehicle speed, throttle input, steering angle and wheel slip to seamlessly deliver torque to the appropriate wheel(s)
- Helps eliminate torque steer and helps balance the vehicle when cornering
- In a curve, the front wheels steer the vehicle to maintain direction, as well as propel the vehicle forward
- AWD system sends power to the rear wheels, allowing the rear wheels to help propel the vehicle
- AWD helps improve overall handling by allowing the front tires to apply more available traction to steer the vehicle
- AWD works together with traction control to distribute up to 100 percent of the available torque to the wheel(s) with the most traction
- System operates as front-wheel drive during normal driving to help reduce fuel consumption

#### A CLOSER LOOK: The Performance of AWD

- All-Wheel Drive uses electromagnetic activation of an internal clutch pack
- It engages when sensors detect wheel slip in the front wheels, and often acts preemptively to prevent slip from happening in the first place
- When activated, the system uses force from an electromagnet to push clutch plates together
- Driveshaft torque is transmitted through the unit to the rear wheels, taking power from the front wheels and sending it to the rear wheels
- System can react within milliseconds to distribute up to 100 percent of the available torque to the rear wheels

#### Rack-and-pinion Steering

- Rack-and-pinion steering maintains linear steering effort as the driver turns the wheel. The result is responsive steering that naturally follows a straight line as the wheel is turned
- 41-foot (curb-to-curb) turning diameter
- Quick steering ratio of 17:1 means drivers don't have to turn the wheel very far to go around a tight corner

#### Four-wheel Disc Brakes

- Large brake rotors (12.8-inch front and 13.0-inch rear) for a large swept area and powerful braking. Front rotors are vented for better heat dissipation, to help reduce brake fade
- Twin-piston front calipers provide a precise and powerful braking performance
- Low-metallic, high-friction brake pad material for durability and dust control. The results are potentially lower maintenance costs and cleaner wheels

#### Electronic Brake Force Distribution (EBD)

- EBD sends the optimum amount of braking pressure to the rear brakes at all times under a variety of loads
- Whether there's one person or five people and their gear, EBD ensures the driver can apply the brakes with confidence in all conditions
- EBD means fewer occurrences of ABS activation and improved braking under heavy loads, and it allows all four wheels to give optimum braking

#### Class III Trailer Tow Package

- Rated to 4500 lbs. and optional on all models
- Receiver hitch and wiring harness with 4-/7-pin connector
- Engine oil cooler
- Tire mobility kit



# 2009 Flex

## Safety/Security

### SAFETY/SECURITY

#### This page is about:

- Accident Avoidance
- Occupant Protection
- Child Safety
- Personal Security

## Overview

### Key Messages

#### Flex



- Flex received the highest 5-star ratings in all crash tests performed by NHTSA<sup>(1)</sup>
- Flex has six standard airbags — dual-stage front, Safety Canopy® System with side curtain airbags and industry-exclusive rollover sensor and front-seat side airbags
- AdvanceTrac® with RSC® (Roll Stability Control™) automatically enhances vehicle control in wet or slippery conditions
- All-Wheel Drive helps provide surefootedness in a variety of road conditions
- Strong unibody structure helps protect occupants in a collision

### Key Features

#### Accident Avoidance

**Available All-Wheel Drive** helps maintain traction in a variety of driving conditions.

**AdvanceTrac with RSC (Roll Stability Control)** helps the driver maintain vehicle control in adverse driving situations or when making evasive maneuvers on slippery pavement.

**All-Speed Traction Control** helps provide control by limiting wheel spin to maximize available traction.

**Four-wheel Anti-lock Braking System (ABS)** prevents wheel lock during excessive braking to help maintain steering control.

**Brake Assist** provides maximum assist when the brakes are applied suddenly but without enough force to provide full deceleration.

**Electronic Brake Force Distribution (EBD)** automatically balances the front-to-rear brake force distribution to reduce the tendency for rear-wheel lockup and optimize braking performance according to vehicle load of passengers and/or cargo.

**Tire Pressure Monitoring System (TPMS)** alerts driver if tire pressure is significantly low.

#### Occupant Protection

##### Six standard airbags

- Dual-stage front airbags
- Safety Canopy® System with rollover sensor
- Front-seat side airbags

**Personal Safety System®** deploys front airbags based on crash severity, safety belt usage, driver's-seat position and a Front Passenger Sensing System that activates/deactivates the passenger airbag dependent upon occupant weight classification.

**Safety Canopy® System with rollover sensor** deploys side curtain airbags for all outboard seating occupants in side-impact and rollover situations.

**Front-seat side airbags** help protect front-seat occupants in certain side collisions.

**Three-point safety belts** for all seating positions.

**Collapsible steering column** collapses in different ways depending on crash severity.

**Energy-absorbing side door trim** helps move crash energy away from occupants.

**Autolock/unlock** locks the doors and liftgate when all doors are closed and the vehicle reaches a speed of 12 mph. Ignition must be in the On position and vehicle in gear for system to function. Doors will automatically unlock when vehicle is placed in Park.

**"Safety cell" construction** utilizes extensive use of high-strength steel to provide a rigid structural cage around the occupants.

**Side-intrusion door beams** help prevent intrusion into the passenger compartment in a side-impact collision.

**Belt-Minder® System** chimes and flashes the safety belt warning light for up to 5 minutes or until the driver and/or passenger fasten their safety belts.

#### Child Safety

**Lower Anchors and Tethers for Children (LATCH) System** provides secure and correct installation of LATCH-compatible child safety seats.

**Rear-door child safety locks** prevent rear-seat occupants from opening the door from the inside.

#### Personal Security

**SecuriLock® passive anti-theft system** uses an electronically coded key (with billions of possible codes) to start the vehicle.

**Perimeter anti-theft system** helps prevent unauthorized entry when the vehicle is locked.

**SOS Post Crash Alert System** activates the hazard flashers and sounds the horn after a crash where the airbags deploy.<sup>(2)</sup> Sounding the horn and flashing the hazards makes the vehicle easier to locate if the accident happened off-road. System operates until deactivated or battery power is depleted.

(1) Star ratings are part of the U.S. Department of Transportation's Safercar.gov program ([www.safercar.gov](http://www.safercar.gov)).

(2) SOS hardware may become damaged or the battery may lose power in a crash, which could prevent operation. Not all crashes will activate an airbag.

**This page is about:**

- AdvanceTrac® with RSC® (Roll Stability Control™)
- Roll Stability Control (RSC)
- All-Speed Traction Control
- Four-wheel Anti-lock Braking System (ABS)
- Brake Assist

# 2009 Flex

## Safety/Security

### Accident Avoidance



#### AdvanceTrac® with RSC® (Roll Stability Control™)

- An electronic stability control system that helps the driver maintain vehicle stability in adverse driving situations or when making evasive maneuvers on slippery pavement
- Components work together to enhance traction and maneuverability by monitoring wheel speed, the Anti-lock Braking System (ABS), acceleration and steering inputs by the driver, and the vehicle rotation around both the vertical yaw and horizontal roll axis
- Onboard computer monitors the sensors and makes adjustments by applying individual brakes and/or modifying engine power to reduce the potential for lost traction or an unstable vehicle situation
- Intervenes progressively so that the driver is hardly aware that AdvanceTrac has been activated
- Greatest benefit is realized when driving on low-traction surfaces or during emergency maneuvers
- Includes Brake Assist
- See the Safety section of the Source Book Appendices for more information

#### Roll Stability Control (RSC)

- RSC is an additional vehicle control software module
- Builds on the ABS, traction control and yaw control systems of AdvanceTrac
- By utilizing a "vehicle roll motion sensor," RSC helps keep the vehicle tires on the ground by monitoring and controlling roll rate

**NOTE:** Please remember that even sophisticated, advanced technologies cannot defy the laws of physics. Encourage safer driving habits to your customers.

#### All-Speed Traction Control

- Uses a combination of brake and/or engine control to maximize available traction on slippery or loose driving surfaces at any speed

#### Four-wheel Anti-lock Braking System (ABS)

- Helps drivers to maintain steering control in emergency or other hard-braking situations
- Electronically "pumps" the brakes several times per second when the computer-controlled sensors indicate wheel lockup during hard braking

#### A CLOSER LOOK: AdvanceTrac with RSC Components

##### Anti-lock Braking System (ABS)

- Allows steering control to be maintained in many hard-braking situations
- Controls wheel lockup to improve stopping in many situations

##### All-speed Traction Control

- Improves traction and acceleration
- Helps tires maintain grip, which aids directional control

##### Yaw Control

- Controls skidding and fishtailing
- Reduces the chance of rollover by reducing yaw motion

##### Vehicle Roll Motion Sensor

- Monitors vehicle body roll angle and how fast the body is rolling from one side to the other at least 100 times per second
- Works to counteract excessive roll by instantly and rapidly applying brake force at the appropriate wheels with a high burst of pressure
- This braking action helps to absorb the roll motion and plant the wheels firmly on the ground

##### Brake Assist

- Recognizes when the brake pedal is applied suddenly but without enough force to provide full deceleration
- With Brake Assist, the system engages the appropriate pressure to maximize vehicle deceleration and help reduce stopping distances
- Without the Brake Assist feature, the result could be a longer stopping distance than desired
- Once the driver releases the brake pedal, the vehicle returns to normal braking mode

#### PRESENTATION TIP: AdvanceTrac with RSC

- AdvanceTrac uses advanced technology to help keep the vehicle on its intended course with all four tires on the road — it knows when to apply brakes to each individual wheel in order to correct a potentially unstable situation
- An example to help customers understand what happens when AdvanceTrac engages is to have them visualize how a bulldozer turns — "steering with brakes"
- AdvanceTrac uses the brakes to help steer the vehicle in certain situations
- When a bulldozer needs to turn right or left, one track moves while the other does not, turning the bulldozer to the left or right, depending on which track moves
- This is an easy way for a customer to understand the technology behind AdvanceTrac

## Accident Avoidance cont'd

### Available All-Wheel Drive (AWD)

- Continuously monitors wheel speed, throttle position and steering-wheel angle to determine the vehicle's conditions and driver's intent. The system then determines the optimal amount of front and rear torque for the given conditions to not only reduce wheel slip but to prevent the slip from occurring in the first place
- Electronically controlled AWD helps keep Flex surefooted in a variety of conditions — slippery surfaces and anything that compromises traction
- Normally functions in front-wheel-drive mode, but the controller continuously monitors information to determine if AWD is needed
- Uses electromagnetic activation of internal clutch plates in the AWD coupling to transfer torque

### AWD Benefits

- No need to activate AWD — it's transparent to the driver and always there when it's needed, for wet or dry pavement, creating driving confidence and peace of mind
- An active on-demand coupler can deliver the precise amount of torque to all four wheels even before the wheels begin to slip
- AWD, paired with AdvanceTrac®, further enhances vehicle stability and driver control
- Since the system can transfer torque away from the front wheels, it helps reduce the type of understeer often associated with front-wheel-drive vehicles, providing improved vehicle control
- When AWD is combined with All-Speed Traction Control or the AdvanceTrac system, a high degree of torque can be sent to the wheel with the best traction, even if the other three wheels have no traction at all

### A CLOSER LOOK: AWD

#### Normal Driving Conditions

- Under normal conditions, AWD operates much like a front-wheel-drive vehicle
- Majority of power is sent to the front wheels
- AWD system continuously monitors throttle position, steering angle and wheel speed to balance the engine's output to the wheel(s) with the best traction

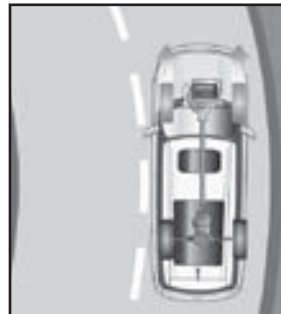

#### Performance and Handling

- In a curve, the front wheels steer the vehicle to maintain direction, as well as propel the vehicle forward
- AWD system sends power to the rear wheels, allowing the rear wheels to help propel the vehicle
- AWD helps improve overall handling by allowing the front tires to apply more available traction to steer the vehicle
- AWD, paired with AdvanceTrac, further enhances vehicle stability and driver control



#### Rain, Sleet or Snow

- Weather conditions can create a slippery patch on the road surface
- When the vehicle encounters these situations, AWD responds proactively within milliseconds, redirecting power to the appropriate wheels with the best traction



#### Sand and Gravel

- It's not uncommon to encounter debris like sand and gravel on the road, which can cause a vehicle to lose traction
- The AWD system proactively compensates for these conditions by immediately sending power to the wheels with the best traction
- This helps the driver to maintain control and drive through the hazard

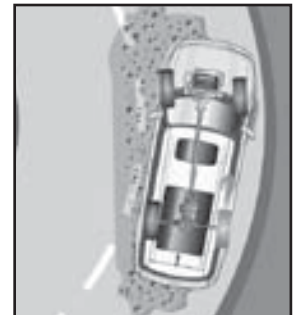

For an online animated demonstration of AWD, go to [esourcebook.dealerconnection.com](http://esourcebook.dealerconnection.com).

## This page is about:

- Tire Pressure Monitoring System (TPMS)
- Personal Safety System®
- Safety Canopy® System with Rollover Sensor

# 2009 Flex



## Safety/Security

### Accident Avoidance cont'd

#### Tire Pressure Monitoring System (TPMS)

- Uses a tire pressure sensor mounted to each road wheel
- Sensors use radio frequency transmitters to send tire pressure information to the vehicle's onboard computer
- The computer illuminates a warning light and sounds an audible tone when tire pressure is significantly low
- System is completely hidden from sight
- Replacing the tire is easily done without removing the sensor
- Provides actual tire pressure readings
- Senses temperature-based pressure loss where all four road wheels are affected
- Resetting the system is easy. Once tire pressure has been restored to its recommended level, TPMS-equipped vehicles simply need to be driven over 20 mph for at least 2 minutes to be reset
- Properly inflated tires help optimize fuel economy and add to a smooth ride
- Recommended tire pressure label is on the driver's door B-pillar

#### ENGINEERING INSIGHT: TPMS Warning Light

ENGINEERING INSIGHT: TPMS Warning Light	
<p><b>Low Tire Warning Light</b></p> <p><b>Solid Warning Light</b></p> 	<p><b>Customer Action Required</b></p> <p>Check tire pressure to ensure proper inflation. Ford recommends a digital or dial-type tire pressure gauge for increased accuracy.</p> <ul style="list-style-type: none"> <li>• After inflating cold tires to manufacturer's recommended pressure as shown on the tire label, the vehicle must be driven for at least 2 minutes at over 20 mph to turn the light off and reset the system</li> <li>• If the light remains on even after these steps have been taken, have the system inspected by the dealership Service Department</li> </ul> <p><b>NOTE:</b> If the outside overnight temperature is significantly lower than the daytime temperature, tire pressure will decrease 1 psi for every 10 degrees F drop in temperature. This may cause the TPMS warning to illuminate. If all tires appear to be inflated, customers should manually check the pressure and inflate all the tires to the recommended cold pressure.</p>
<p><b>Flashing Warning Light</b></p> 	<ul style="list-style-type: none"> <li>• Driving on the spare tire may activate the TPMS warning light, causing it to flash for 75 seconds followed by a solid light. Repair the damaged road wheel and remount it on the vehicle. Reset the TPMS by driving at over 20 mph for at least 2 minutes</li> <li>• If the tires are inflated to the manufacturer's recommended pressure and the spare tire is not in use, have the system inspected by the Service Department</li> <li>• See the vehicle Owner's Guide for more information</li> </ul>

### Occupant Protection

#### Personal Safety System®

The Ford Personal Safety System tailors airbag usage to the severity of the crash, driver and passenger safety belt use, driver's-seat position and passenger classification. System components include:

- Dual-stage driver and front passenger airbags
- Electronic front crash severity sensor
- Driver's-seat position sensor
- Front outboard safety belt usage sensor
- Restraint Control Module
- Front outboard safety belt energy management retractors
- Front outboard safety belt pretensioners
- Front Passenger Sensing System

See the Safety Section in the Appendices book for more information on the Personal Safety System.

#### Safety Canopy® System with Rollover Sensor

- Side curtain airbags provide head protection for all outboard seating positions
- System includes side curtain airbags and rollover sensor
- Located in the roof side rail behind the headliner, the side curtain airbags deploy downward and outward toward the side window opening to protect the heads of outboard passengers in all three rows
- Side air curtains are triggered independently of the driver and front passenger airbags by side-impact sensors or by the rollover sensor
- Roll-fold technology helps the airbag slide between the glass and occupant as it inflates
- Side curtain airbags will not interfere with properly installed child safety seats or booster seats
- Canopy is designed to stay inflated longer for added protection in a rollover or multiple side impacts

# 2009 Flex

## Safety/Security

### SAFETY/SECURITY

#### This page is about:

- Front-seat Side Airbags
- Roll-fold Technology
- Lower Anchors and Tethers for Children (LATCH) System
- SecuriLock® Passive Anti-theft System
- Perimeter Anti-theft System
- 24-Hour Roadside Assistance

## Occupant Protection cont'd

### Front-seat Side Airbags

- Side-impact airbags help protect front-seat occupants in certain side collisions
- Airbags deploy from the front seats to protect occupants' chest
- Placed in the front seatbacks, so they are always in the optimum deployment position no matter where the seat is positioned
- Designed to help protect the chest in certain side collisions



### PRESENTATION TIP: Roll-fold Technology

One of the keys to Flex's outstanding safety protection is the side curtain airbags included in the Safety Canopy® System. These airbags are concealed in the headliner and employ roll-fold technology to help ensure proper deployment during certain side-impact collisions and rollovers. You can demonstrate how this safety feature functions using a simple "blow-out" or "roll horn" party favor since it uses the same basic principles as the roll-fold technology.

Give it a try:

- Insert the roll horn into your mouth and inflate it
- Air pressure enters the horn and flows out to unfold and inflate (or pressurize) the rolled end of the horn
- Consider tilting your head down while inflating the horn to demonstrate the downward deployment of the airbag along the side of the window
- Explain to the customer before or after you inflate the horn — sensors inflate the side curtain airbags in a fraction of a second — what they're seeing happens faster than the eye can see
- While the unfolding and inflating process is nearly impossible to see with the naked eye, the rolled party favor works much the same way

## Child Safety

### Lower Anchors and Tethers for Children (LATCH) System

- Consists of a top tether anchor point and two rigid bars located where the seat cushion meets the seatback
- Three upper anchorages are available:
  - Three in the second row with 60/40 bench seat
  - Two in the second row with 40/40 bucket seats
  - One in the third row on the passenger side
- LATCH-compatible child safety seat attaches to the lower anchor points by means of flexible tethers or rigid latch bars
- LATCH assists in providing a secure attachment and uniform installation method to help reduce the likelihood of an improper child safety seat installation

## Personal Security

### SecuriLock® Passive Anti-theft System

- Uses an electronically coded ignition key (with billions of possible codes to start the vehicle)
- Designed to help prevent the engine from being started unless a coded key programmed to the vehicle is used

### Perimeter Anti-theft System

- Monitors against unauthorized entry of the doors, hood or liftgate when the vehicle is locked

### 24-Hour Roadside Assistance

- Toll-free number (1-800-241-FORD) operational 24 hours, 7 days a week
- Customers can request services to change a flat tire, jump-start a battery, deliver fuel or tow the vehicle
- Available for 5 years or 60,000 miles, whichever comes first

# 2009 Flex

## Quality/Reliability/Durability

**This page is about:**

- Noise, Vibration and Harshness (NVH)
- Easy Maintenance
- New Vehicle Limited Warranty
- 5-year/60,000-mile Powertrain Limited Warranty
- 24-Hour Roadside Assistance

### Overview

#### Key Messages

**Flex**



- 90,000-mile spark plug maintenance interval<sup>(1)</sup>
- Self-adjusting accessory drive belt is rated for 150,000 miles of normal service
- 3-year/36,000-mile Bumper-to-Bumper warranty with no deductibles
- 24-Hour Roadside Assistance

#### Key Features

##### Noise, Vibration and Harshness (NVH)

**Laminated windshield** helps lower wind noise levels.

**Laminated front side-door glass** on Limited models further improves the quiet interior environment.

**Roll-axis engine mounts** help reduce powertrain NVH levels.

##### Easy Maintenance

- Stainless-steel exhaust system helps resist corrosion
- 6-month/7,500-mile oil change interval
- Spark plugs rated for 90,000 miles<sup>(1)</sup>
- Duratec's self-adjusting accessory drive belt is rated for 150,000 miles<sup>(1)</sup>
- Sealing systems and gaskets rated for up to 15 years of service<sup>(1)</sup>
- "Filled-for-life" transmission fluid<sup>(1)</sup>

##### Warranty

###### New Vehicle Limited Warranty

- 3-year/36,000-mile Bumper-to-Bumper; no deductible
- 5-year/60,000-mile Powertrain Limited Warranty
- 5-year/unlimited-mileage Corrosion Perforation
- 5-year/60,000-mile Safety Restraint

###### 5-year/60,000-mile Powertrain Limited Warranty

- Powertrain Limited Warranty for Ford vehicles is 5 years or 60,000 miles, whichever comes first
- That's an additional 2 years/24,000 miles of coverage for components such as the engine, transmission and front- and rear-wheel-drive parts beyond the vehicle's 3-year/36,000-mile Bumper-to-Bumper Limited Warranty
- Refer to the vehicle Warranty Guide for a complete list of all of the parts covered

###### 24-Hour Roadside Assistance

- Toll-free number (1-800-241-FORD) operational 24 hours a day, every day
- Customers can request services to change flat tire, jump-start battery, unlock vehicle, deliver fuel or tow vehicle
- Available for 5 years or 60,000 miles, whichever comes first



<sup>(1)</sup> Under normal driving conditions.

### Audio/Navigation/Entertainment

This page is about:

- AM/FM Stereo/Single-disc CD Player
- AM/FM Stereo/6-disc In-dash CD Changer with SIRIUS® Satellite Radio
- Sony® Premium AM/FM Stereo/6-disc In-dash CD Changer with SIRIUS Satellite Radio

#### All Flex Audio Systems Include

- MP3 capability
- Autoset (AST) automatically locates the 6 strongest AM or FM station signals
- Seek/Scan
- Auxiliary audio input jack

#### AM/FM Stereo/Single-disc CD Player

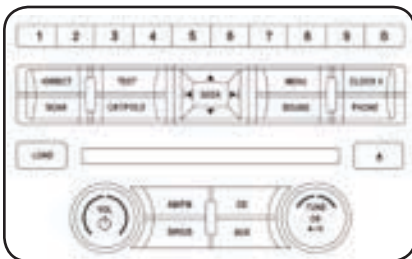

- 80 watts of power
- 6 speakers
- 30 station memory presets (20 FM and 10 AM)
- **Speed Compensated Volume (SCV)**
  - Compensates for changing ambient noise levels by adjusting the volume of the radio according to the vehicle's speed signal
  - Allows a choice of 7 volume adjustment levels and is adjustable through the menu
- **RDS (Radio Data System) function** allows the following:
  - Radio station call letters appear on radio display
  - Type of music format appears on radio display
  - Search for type of music format
  - Only for FM radio stations supporting RDS capability
- **Compression** allows the audio dynamic range to be compressed so quieter music is boosted and louder music is lowered to compensate for ambient noise level when enabled during CD mode
- **Occupancy setting** allows for one of three vehicle acoustic settings to be chosen
- **Repeat** will play the selected track continuously until Repeat is deactivated when enabled during CD mode
- **Shuffle** plays CD/MP3 tracks in random order
- **Folder/track** mode allows the audio system to play and seek through disc tracks with or without folder option (available with MP3 discs only)

#### AM/FM Stereo/6-disc In-dash CD Changer with SIRIUS® Satellite Radio

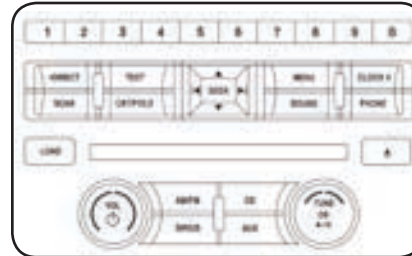

In addition to the AM/FM stereo/single-disc CD player, includes:

- 6-disc CD changer
- Traffic information broadcasts for the RDS System
- SIRIUS Satellite Radio

#### Sony® Premium AM/FM Stereo/6-disc In-dash CD Changer with SIRIUS Satellite Radio

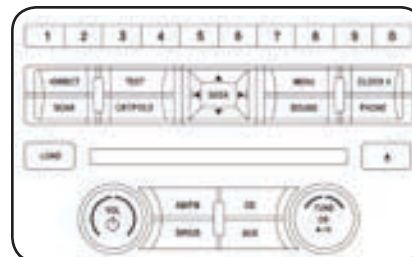

In addition to the AM/FM stereo/6-disc in-dash CD player with SIRIUS Satellite Radio, includes:

- 390 watts of power
- 12 premium speakers, including a subwoofer (in 10 locations)<sup>(1)</sup>
- 2 amplifiers (1 for subwoofer)
- Certified for Ford by Sony for best sound performance
- Delivers a unique, rich, clear sound
- Dolby® Surround Sound
  - 5.1 with DVD audio source
  - Simulated surround sound with all other sources (radio, CDs, etc.)

(1) Two rear-door speakers are a coaxial design that combines a woofer and tweeter in one speaker.

#### For More Audio Information

- Audio availability: See the latest Dealer Ordering Guide
- Operating information: See the vehicle Owner's Guide

## This page is about:

- Voice-activated Navigation System with SIRIUS® Travel Link™
- SIRIUS Travel Link

## Audio/Navigation/Entertainment

## Voice-activated Navigation System with SIRIUS® Travel Link™



- Includes a single-disc version of the Sony® Premium audio system with:
  - 18 station memory presets (12 FM and 6 AM)
  - 18 satellite radio station memory presets
- **Voice activation** recognizes certain voice commands to operate the system hands-free<sup>(1)</sup>
- **Large 8-inch LCD touch screen** operates navigation and audio functions
- Integrated **climate control** functions
- Includes **Rear View Camera System**
  - Automatically engages when vehicle is placed in Reverse
  - Camera is located in the liftgate under the Ford logo
  - Video is shown on the Navigation System screen
- **Traffic and weather information, fuel pricing, sports updates and movie listings** provided by SIRIUS Travel Link. Learn more about the capabilities in the "A Closer Look" box at right
- **Bird's-eye map** provides a "3D" view of route, landmarks and Points of Interest (POI)
- **Music Jukebox capability** allows for 10 GB of storage and access to around 2,400 songs (at 4 minutes per song)
  - Browse the music library via the touch screen or by voice recognition
  - Music can be sorted by playlists
- **Park and Play** mode allows DVDs to be played while vehicle is in Park
- **Upload photos** to the home screen
- **Destination selection search** methods include:
  - Street address
  - Increased Points of Interest (POIs) including retail
  - Freeway entrance/exit search
  - Previous destination
- **Route Guidance** with turn-by-turn voice directions
  - Street name announcements
  - Freeway exit, turn and ramp transition lane guidance
  - Speed limit display on freeways
- Supports North American English, Canadian French and Mexican Spanish
- **Help menu** for basic operation, driving restrictions and navigation DVD

- **Automatic rerouting** recalculates a new route if a turn is missed
- **Emergency button** provides nearest emergency facility to choose as a destination (hospital or police)
- **Valet Lockout Mode** disables operation of the navigation and audio systems
- **Address book** saves the most frequently used destinations for quick and easy routing
- **Hard-drive-based system** includes 10 GB of storage for photos and music

A CLOSER LOOK:  
SIRIUS Travel Link<sup>(1,2)</sup>

- **Real-time traffic info**
  - Provides incident, speed and flow information for 80 major cities in the continental U.S.
  - Updates every 2.5 minutes
  - View graphical overlay of incidents
  - Route recalculation based on traffic data
- **Real-time weather info**
  - Provides current weather and 5-day forecast reports that are updated every 5 minutes
  - Current conditions update every 30 minutes
  - Region of interest can be defined by customer
- **Fuel pricing** for over 120,000 gas stations
  - Search for pricing en route or based on current location
  - Displays pricing for regular, mid-grade and premium when available
- **Sports updates and movie listings**
  - Score summaries and schedules for major sports
  - Updates every 5 minutes
  - User can personalize for favorite teams
  - Movie listings for over 4,500 theatres, including times, movie summary and directions to the theatre
- 6-month complimentary subscription<sup>(3)</sup> subject to location and availability included with Navigation System
- More information is available online at [www.sirius.com](http://www.sirius.com) or toll-free at (888) 539-SIRIUS (7474)

(1) Driving while distracted can result in loss of vehicle control. Only use mobile phones, navigation systems and other devices even with voice commands, when it is safe to do so.

(2) Real-time traffic monitoring available in select markets. Some features may not be available while the vehicle is in motion. Service not available in Alaska or Hawaii. SIRIUS is a registered trademark of SIRIUS Satellite Radio, Inc.

(3) SIRIUS Satellite Radio and SIRIUS Travel Link are separate subscriptions.

## For More Audio Information

- Audio availability: See the latest Dealer Ordering Guide
- Operating information: See the vehicle Owner's Guide

**Audio/Navigation/Entertainment****This page is about:**

- SIRIUS® Satellite Radio —
- DVD Entertainment System —
- Auxiliary Audio Input Jack —

**SIRIUS® Satellite Radio**

- Includes 6 months of SIRIUS service subject to location and availability
- Order Code 581 must be specified for the SE. This will equip the vehicle with the AM/FM stereo/6-disc in-dash CD changer and necessary vehicle-to-radio interface and antenna
- Unit is preactivated from the factory
- SIRIUS Satellite Radio can be accessed using existing radio head controls:
  - **Aux button** — press and release to enter satellite radio mode
  - **Seek/Scan** — use these buttons to change channels
- Key benefits of SIRIUS Satellite Radio include:
  - Over 130 channels of the best music, talk, news, sports and information (65 music channels)
  - 100 percent commercial-free music
  - Seamless coverage anywhere in the contiguous U.S.
- More information is available online at [www.sirius.com](http://www.sirius.com) or toll-free at (888) 539-SIRIUS (7474)

**DVD Entertainment System**

- DVD player
- 8-inch LCD screen folds down from the headliner
- Backlit controls for nighttime operation
- Two wireless headphones
  - Two additional input jacks for wired headphones
- Infrared remote control with illuminated keypad
- Dual-media feature allows front-seat passengers to listen to radio or CDs while rear-seat passengers watch a movie or play video games
  - Two channels also allow separate media usage between headphones
- Universal RCA audio/video input jacks allow use of other equipment such as media players and video games
- Plays MP3, CD-R, CD-R/W, DVD-R and DVD-R/W formats
- Engineered and durability tested for in-vehicle use with skip protection, shake resistance and temperature tolerance

**NOTE:** Any other equipment requires the use of a power adapter. The DVD player provides the audio/video input jacks, but not the power source.

**Auxiliary Audio Input Jack**

- Standard on all models
- Located in the center console
- Allows the use of portable MP3 players
- Includes USB port auxiliary jack on vehicles equipped with Ford SYNC®

**For More Audio Information**

- Audio availability: See the latest Dealer Ordering Guide
- Operating information: See the vehicle Owner's Guide





## WHEELS

### This page is about:

- 18" Painted Aluminum
- 17" Aluminum
- 18" Machined Aluminum
- 19" Polished Aluminum
- 20" Bright Painted Aluminum

# 2009 Flex Wheels

## Wheels

Wheel		SE	SEL	Limited
18" Painted Aluminum Wheel		S	—	—
17" Aluminum Wheel <sup>(1)</sup>		O	—	—
18" Machined Aluminum Wheel		—	S	—
19" Polished Aluminum Wheel		—	—	S
20" Bright Painted Aluminum Wheel (late availability)		—	O	O

— = Not available      S = Standard      O = Optional

(1) Available only in snow states or states requiring tire chains.

**NOTE:** See the latest Dealer Ordering Guide for wheel availability.

### Interior Trim/Instrument Cluster

This page is about:

- Interior Trim
- Instrument Cluster

### Interior Trim

Interior Trim Type and Color Selector NOTE: First character denotes type, second character denotes color.	Interior Trim Colors	
	Medium Light Stone	Charcoal Black
<b>SE</b> Cloth Seats	CS	CW
<b>SEL</b> Leather-trimmed Seats	LS	LW
<b>Limited</b> Perforated Leather-trimmed Seats	PS	PW

NOTE: See the 2009 Color and Upholstery Album or the Specifications section of eSourceBook ([esourcebook.dealerconnection.com](http://esourcebook.dealerconnection.com)) for illustrations of the available seating choices.

Flex

### Instrument Cluster

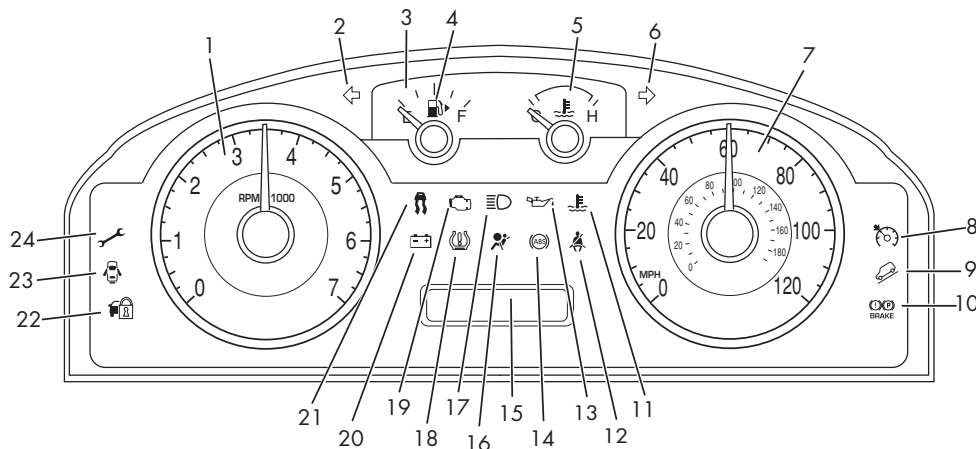

- |  |  |  |
|--|--|--|
| 1. Tachometer  | 11. Engine coolant temperature warning light                         | 18. Low tire pressure warning light                      |
| 2. Left turn signal indicator                          | 12. Fasten safety belt warning light                                 | 19. Service engine soon warning light                    |
| 3. Fuel gauge  | 13. Low engine oil pressure warning light                            | 20. Charging system warning light                        |
| 4. Fuel filler door location indicator                 | 14. Anti-lock Braking System (ABS) readiness indicator/warning light | 21. AdvanceTrac®/Traction Control active indicator light |
| 5. Engine coolant temperature gauge                    | 15. Message center   | 22. Anti-theft system active indicator                   |
| 6. Right turn signal indicator                         | 16. Airbag readiness indicator/warning light                         | 23. Door ajar warning light                              |
| 7. Speedometer   | 17. High-beam indicator  | 24. Throttle control/transmission fault warning light    |
| 8. Cruise control active indicator                     |  |  |
| 9. Overdrive cancel and grade assist indicator light   |  |  |
| 10. Brake system warning light/parking brake indicator |  |  |

**Model**

Wheelbase	117.9
Length	201.8
Height, excluding options	68.0
Width, including mirrors	88.8
Track (Front/Rear)	65.4/65.4
Base Curb Weight (approx. lbs.)	
Front-Wheel Drive	4468
All-Wheel Drive	4640

**Seating**

Capacity	6/7
Head Room (Front/Middle/Rear)	41.8/40.5/38.7
Shoulder Room (Front/Middle/Rear)	58.4/58.1/50.8
Hip Room (Front/Middle/Rear)	55.5/55.0/41.1
Leg Room (Front/Middle/Rear)	40.8/44.3/33.3

**Passenger/Luggage/Fuel Capacity**

Passenger Volume (cu. ft.)	155.8
Interior Volume, 3rd row folded (cu. ft.)	175.8
Cargo Capacity (cu. ft.)	
– behind 1st row	83.2
– behind 2nd row	43.2
– behind 3rd row	20.0 <sup>(2)</sup>
Fuel Tank Capacity (gal.)	18.6

**Engine**

Layout	Front-Wheel Drive/All-Wheel Drive
Engine Type	Duratec 35 — 3.5L DOHC V6
Displacement (liters/cu. in.)	3.5/213
Horsepower @ rpm	262 @ 6250
Torque (lb.-ft. @ rpm)	248 @ 4500
Compression Ratio	10.3:1
Bore and Stroke	3.6 x 3.4
Fuel System	Sequential Multi-port Fuel Injection
Fuel Requirement	87 octane (minimum)
Fuel Economy (city/hwy. mpg)	17/24 (FWD) 16/22 (AWD)
Exhaust System	Dual stainless steel w/catalytic converter

**Transmission**

Type	Electronically Controlled 6-speed Automatic					
Gears	1st	2nd	3rd	4th	5th	6th
6-Speed Automatic	4.48:1	2.87:1	1.84:1	1.41:1	1.00:1	0.74:1
	Rev.					
	2.88:1					
Final Drive Ratios						
Front-Wheel Drive	3.16:1					
All-Wheel Drive	3.39:1					

**Front Suspension**

Type	Independent MacPherson struts with rear-facing L-shaped lower control arm and stabilizer bar attached to an isolated subframe
Springs	Helical coil
Shock Absorbers	Integrated with strut, gas-pressurized hydraulic
Stabilizer Bar Diameter	32mm

**Rear Suspension**

Type	Independent multi-link with upper and lower control arms and isolated stabilizer bar
Springs	Helical coil with isolating upper and lower spring seats
Shock Absorbers	Gas-pressurized hydraulic
Stabilizer Bar Diameter	22mm

**Steering**

Type	Power rack-and-pinion
Overall Ratio	17:1
Turning Diameter Curb-to-Curb (ft.)	40.7

**Brakes**

Standard	Four-wheel disc with Anti-lock Braking System (ABS), Panic Brake Assist and Electronic Brake Force Distribution (EBD)
----------	---

**Trailer Towing<sup>(3)</sup>**

Towing Class	Light-duty Class I (standard)/Class III (optional)
Gross Trailer Weight (lbs.)	2000/4500
Maximum Tongue Weight (lbs.)	200/450
Hitch Design	Load-carrying

**Neutral Towing****Flat Tow/Neutral Tow**

Also known as four-wheel-down towing, it refers to towing a vehicle with all four of its wheels on the ground — for example, when towing a vehicle behind a motorhome. All Flex models can be neutral towed. ONLY Flex FWD models can be dolly towed (front wheels OFF the ground). NEVER dolly tow a Flex with AWD. See the vehicle Owner's Guide for complete details.

(1) Dimensions are in inches unless otherwise specified.

(2) Includes 5.0 cu.-ft. rear seat well.

(3) For more towing information, see the vehicle Owner's Guide.